

Joint Improvement Team

National Telecare Programme

Report

The Future Direction of Telecare Call Handling Services in Scotland with regards to Changing Technologies, Expectations and Demand

Telecare Think Tank 

CONTENTS

1. EXECUTIVE SUMMARY	3
2. INTRODUCTION	5
2.1 BACKGROUND.....	5
2.2 THE COMPONENTS OF A TELECARE SERVICE.....	6
2.3 SCOTLAND'S CURRENT CALL HANDLING ARRANGEMENTS	10
2.4 DRIVERS FOR CHANGE.....	12
2.5 SCOPE OF REPORT	13
3. TECHNOLOGY DRIVERS	14
3.1 INTRODUCTION.....	14
3.2 TELECARE EQUIPMENT (PERIPHERALS)	15
3.3 HOME-BASED CONNECTIVITY	17
3.4 HOME-HUB.....	18
3.5 TELECOMMUNICATIONS NETWORK.....	19
3.6 TELECARE MONITORING & CALL-HANDLING SYSTEMS	20
3.7 KEY POINTS.....	24
4. CALL-HANDLING SERVICES	27
4.1 BASIC COMMUNITY ALARM SERVICES – INTRODUCTORY TELECARE.....	27
4.1.1 <i>Sheltered Housing</i>	28
4.1.2 <i>Supporting People</i>	28
4.1.3 <i>Advanced Telecare to Replace Introductory Telecare</i>	29
4.1.4 <i>The Use of Mobile Phones</i>	30
4.1.5 <i>The Penetration Potential</i>	31
4.1.6 <i>Overall Impact</i>	32
4.2 EXTENDED ALARM-BASED TELECARE	34
4.2.1 <i>Implications for Call Handling</i>	34
4.2.2 <i>Summary</i>	35
4.3 LIFESTYLE MONITORING	35
4.3.1 <i>Introduction</i>	35
4.3.2 <i>Overall Growth Potential</i>	37
4.3.3 <i>Summary</i>	38
4.4 TELEHEALTH	39
4.4.1 <i>Introduction</i>	39
4.4.2 <i>Telehealth Equipment & Systems</i>	39
4.4.3 <i>The Potential for Growth</i>	40
4.4.4 <i>Impact on Monitoring Centre</i>	41
4.4.5 <i>Summary</i>	44
4.5 PROACTIVE CALLING	44
4.5.1 <i>Introduction</i>	44
4.5.2 <i>Impact Summary</i>	45
4.6 DOMICILIARY CARE MONITORING.....	45
4.6.1 <i>Introduction</i>	45
4.6.2 <i>Extending the Application</i>	46
4.6.3 <i>Impact on Call Handlers</i>	46
4.7 ACCESS MANAGEMENT.....	47
4.7.1 <i>Background</i>	47
4.7.2 <i>Role of Monitoring Centre</i>	48
4.8 LOCATION BASED SYSTEMS.....	48
4.8.1 <i>Background</i>	48
4.8.2 <i>Tracking and Location Technologies</i>	49
4.8.3 <i>Locating People Inside Properties</i>	49
4.8.4 <i>Impact on Alarm Handling Centres</i>	50
4.9 EXISTING/EMERGING APPLICATIONS OF TELECARE	50
4.9.1 <i>Supported housing</i>	50

4.9.2 School and Public Building Security.....	51
4.9.3 Criminal Justice System.....	52
4.9.4 Fire Protection.....	52
4.9.5 Lone Worker Protection.....	53
4.10 VIDEO-BASED SUPPORT SERVICES.....	54
4.10.1 Background to Services.....	54
4.10.2 Impact on Monitoring Centre.....	55
4.11 REVIEW OF IMPACT OF FUTURE TELECARE ON CALL HANDLING SERVICES.....	55
5. DISCUSSION.....	56
5.1 ISSUES CONCERNING SERVICE CAPACITY.....	56
5.1.1 Target Groups.....	56
5.1.2 Levels of Intervention.....	57
5.1.3 Impact of Interventions on Resources.....	59
5.2 FINANCIAL ISSUES.....	62
5.3 QUALITY & RESOURCE ISSUES.....	62
5.3.1 Service Specifications & The Quality Agenda.....	62
5.3.2 Staff Roles, Profile & Training.....	66
5.3.3 The Cost of Monitoring Quality.....	71
5.3.4 Monitoring Centre Premises & Support.....	72
5.3.5 Marketing and Other Management Issues.....	74
5.3.6 Alternative Models to Community Alarms.....	75
6. MODELS FOR FUTURE ALARM HANDING CENTRES.....	77
6.1 MATCHING SERVICES TO CAPABILITIES, COMPATIBILITIES AND VISION.....	77
6.2 SMALL SINGLE AUTHORITY.....	78
6.3 REGIONAL.....	81
6.4 LARGE CITY.....	82
6.5 VIRTUAL ALARM HANDLING CENTRE OPTIONS.....	83
6.6 SUMMARY.....	84
7. CONCLUSIONS & RECOMMENDATIONS.....	85
7.1 FINANCIAL VIABILITY.....	85
7.2 IMPROVING PERFORMANCE.....	86
7.3 LOCAL PARTNERSHIP VISION.....	87
7.4 BUSINESS PLANS.....	88
8. APPENDICES.....	91
8.1 SECTION 2 - INTRODUCTION.....	91
8.1.1 Telecare Call-Handling Arrangements across Scotland.....	91
8.1.2 Anticipated Changes in the Composition of Households in Scotland.....	92
8.2 SECTION 3 – TECHNOLOGY DRIVERS.....	94
8.2.1 Future Connectivity & Sensor Platforms in the Home.....	94
8.2.2 The Home Hub of the Future.....	95
8.3 SECTION 4 – CALL-HANDLING SERVICES.....	97
8.3.1 Mobile Phones for Older People.....	97
8.3.2 New Sensor Systems.....	99
8.3.3 Health Coaching in Birmingham.....	100
8.3.4 Key-safes and Electronic Access Methods.....	101
8.3.5 Tracking Technologies.....	102
8.3.6 Amego & Alert Me Systems.....	105
8.3.7 Lone Worker Systems.....	106
8.3.8 Lifestyle Monitoring.....	107
8.3.9 Telehealth Application Example.....	111
8.4 SECTION 5 – DISCUSSION.....	112
8.4.1 Financial Analysis of Telecare Services.....	112
9. REFERENCES.....	123

1. Executive Summary

Telecare services are developing quickly in Scotland but there are significant variations across the 24 telecare alarm handling centres being employed. These reflect differences in scale, from centres with fewer than a thousand connections, through to national centres with tens of thousands of connections, and differences in the range of applications being offered. The nature of telecare services, and hence of the call handling centres, will change over the next few years. There are demographic and policy drivers that will see more people with greater levels of need using telecare services as a support mechanism that enables them to exercise choice and to continue to live independently in their own homes. Technology developments are also imminent; they will extend the range of telecare services, facilitating a shift of emphasis from reactive systems that respond to emergencies to more predictive and responsive systems (such as Lifestyle Monitoring and Telehealth) that encourage prevention and health promotion. More sophisticated applications for these technologies will emerge with an increasing focus on health and social care.

In discussing the effects of these changes on the different models of call-handling centre used in Scotland, this report offers some ideas on how they might cope with the likely demand for such services and the cost of servicing these needs. It concludes that:

- Staffing models will need to change;
- The quality agenda will demand more staff capable of providing more added value services;
- Training will become an increasing burden; and
- More specialist roles (such as alarm handler, installer and emergency responder) will emerge.

The overall impact of the changes is considered on each of the four current call handling centre types: small local, regional, big city and national. It is concluded that the small local centres will come under increasing financial pressure because they will be unable to afford the capital and staff investments needed to expand service provision for an increasing proportion of service users. Regional centres may become the preferred model of provision, offering sufficient connections to achieve economies of scale whilst extending partnership working across local authority boundaries. Larger centres will have the capacity to provide not only remote telemonitoring services for vital signs but also health coaching services involving the employment of nurses and other healthcare delivery staff within the alarm handling centre to support chronic disease management.

13 recommendations are made:

- 1. Develop costs template for consistent reporting across all partnerships.**
- 2. Collect results of internal cost reviews from all centres.**
- 3. Establish a Scottish performance management system for alarm handling centres.**
- 4. Investigate the potential of establishing a training board to oversee development of accredited courses and modules.**
- 5. Encourage local partnerships to produce a strategic vision identifying the scope of telecare applications.**
- 6. Local partnerships seek to identify local champions to promote telecare strategies within councils, health boards and across the wider community.**
- 7. Information packs are prepared to explain the features and benefits to elected members who may have limited professional knowledge of the health and care sector.**
- 8. Actively seek buy-in from health boards and trusts, RSLs and councils.**
- 9. Prepare marketing and promotional plan for services.**
- 10. Local partnerships put in place a robust management structure to ensure that business plans are reviewed and updated on an annual basis, and actions taken as appropriate to achieve success.**
- 11. Business plans follow a standard format and should include targets for the next 5 years.**
- 12. Local partnerships undertake annual reviews and external evaluations of services using a standard framework; and**
- 13. Local partnerships ensure that the services that are offered to private individuals are properly costed so that they offer good value for money for both the individuals and for the health and social care economies.**

2. Introduction

2.1 Background

Telecare services have evolved in Scotland over the past decade from social alarm systems which have been in existence for over 25 years. They have benefited from capital funding allocated by the Scottish Government to partnerships across the country which have produced clear plans to expand services over the next few years. It has already been shown that these services can be cost effective in helping to avoid unnecessary use of hospital beds. Significant other benefits are also possible to a wider group of stake holders.

The infrastructure adopted for telecare in Scotland has been that of the social alarm systems which, in most cases, offers local call handling, in some place accompanied by local installation and response services. There have been no formal and robust studies to investigate the quality and the cost-effectiveness of telecare service provision using the social alarm infrastructure. This is not surprising as there are few bench-marks available for monitoring the performance of services as formal specifications have yet to be developed. In the same way, the operational costs and the benefits of running telecare services remain something of a mystery because of a lack of transparency or consistency in the allocation of funding, and because charging strategies are somewhat arbitrary, not only in Scotland but also across the UK.

Yet, telecare services are likely to evolve quickly both due to the push of technology and due to the pull of demographic trends, policy objectives regarding the location of care, the choice agenda for individuals, plus an expectation that care services must improve with time. A consequence is that social alarm services have probably changed more over the past 5 years than they have done in the previous 25 years. As the pace of technology and the drive towards supporting independent living at home increases, the rate of change is unlikely to slow. As a consequence, the structure of telecare services will inevitably need to adapt in order that they are responsive to local needs, but also efficient in terms of delivery services without excessive cost neither to the NHS, nor to local authorities or service user. Central to each service is the alarm call handling centre. The range of functions that it offers must also change as new applications are offered. Not all centres will want to, or will be in a position to, offer all applications. Income streams for centres will therefore be different across the country.

The purpose of this study is to establish the future direction of telecare call handling services in Scotland with regards to changing technologies, expectations and demand. This will be achieved by considering:

- the technology drivers and how these will change the cost and scope of service delivery;
- examples of new services that are developing to exploit technological innovations;

- resource requirements for these services looking specifically at the skills required and training issues associated with additional roles and responsibilities;
- opportunities for extending alarm-handling roles to include emergency protocols to deal with a broader range of client groups and risk situations;
- screening telephone calls and video consultations for other health and social work organisations with appropriate referrals to other agencies (including call centres) for further advice and interventions;
- provision of advice and counselling for people who need to adopt lifestyle changes in order to promote their health and well-being; and
- the development of more flexible working practices that will enable alarm-handling staff to respond to new models of service delivery and performance management.

This leads us to make a number of recommendations to Scottish alarm handling centres aimed at helping them to consider their plans for the future in the light of likely developments and threats to their business. We begin by looking at the situation today in order to establish the baseline for our analysis, and to understand the scope of our assessment.

2.2 The Components of a Telecare Service

It is important to realise that telecare is much more than a technology. It is essentially a social support function that just happens to use a technology-based platform and which is highly dependant on skilled staff and on robust operating procedures and protocols. In order to provide a bone-fide telecare service to members of the public, a number of support functions or processes need to be provided. Often, this requires a re-configuration of existing services or processes to enable new forms of working to be developed.

Irrespective of how a service is configured, it can usually be considered in terms of five *principal components*, Figure 1, namely:

1. The telecare 'service provider';
2. The telecare monitoring centre;
3. A community response element or service;
4. The operational protocols and procedures in use; and
5. The telecare applications and technologies employed (in the home and in the monitoring centre).

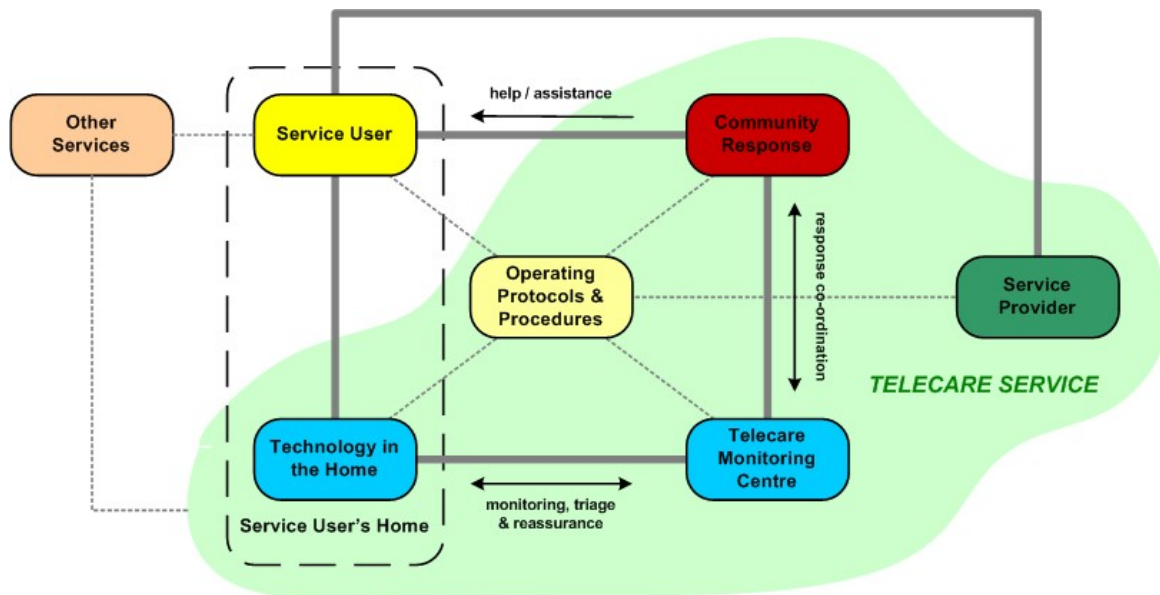

Figure 1. The principal components of a telecare service.

The provision of an effective level of telecare depends on the capabilities and efficacy of these five principal components working seamlessly together. Each component has an important role to play and is discussed briefly below:

- **Telecare 'Service Provider'** – Within the current context, the 'service provider' refers to the facilitator or enabler of the service. Some of the roles included as part of the service provider are:
 - i. service promotion;
 - ii. accepting referrals and enquiries;
 - iii. assessing need and identifying appropriate telecare applications and technologies to meet that need;
 - iv. procuring, installing & testing equipment; reviewing needs as required; and
 - v. co-ordinating the telecare process.

In practice, these roles might be distributed across a number of separate professions and organisations.

- **Telecare Monitoring Centre** – a call centre equipped to handle the alarm calls & data generated by the equipment in the homes of service users. In most instances, the monitoring centre equipment can also be used to remotely program devices in the homes of service users. The centre has skilled call-handlers who are trained to provide reassurance to service users and to elicit the necessary information with which to identify their needs in the event of an alarm call. These staff are responsible for arranging and co-ordinating the most appropriate response to each

call. It may also be used to initiate calls of a proactive nature, and to host data collected remotely from equipment in the community. These data may be analysed and presented in a form suitable for publishing.

- **Community Response** – for situations where a physical community-based response is required in the home of the service user. This response might be provided by informal carers (key-holders), by a dedicated 24/7 response team or by one of the emergency services . A few local partnership in Scotland have established new 24/7 response teams.
- **Operational Protocols & Procedures** – rules and procedures which define the behaviour of each element of the system including how they should interact and share data with each other and how the system should respond to particular events and circumstances.
- **The Telecare Applications & Technology In Use** – It may be apparent that the technology in the home of the service user will define the characteristics of the telecare service for that user and will typically consist of a combination of: stand-alone electronic assistive technologies (e.g. motion-activated reminder units, medication reminders & dispensers, automatic lighting, etc.); alarm pendants & sensors (e.g. pull-cords, fall detectors, gas sensors, flood & smoke sensors, etc.); actuators (e.g. gas & water valves, X-10 based home automation) and user-interface/controls. These elements combine together with a home unit incorporating a degree of intelligence, a home-based wireless communications platform and an external telecommunications link to provide the necessary telecare applications. Numerous technological devices and solutions exist from various manufacturers to help meet these varied needs, not all of which are compatible with each other.

In the telecare monitoring centre, the call-handling system must be suitably equipped to receive, accurately decode and display the alarm information and related data from the equipment installed in the field. In most instances, the monitoring centre equipment can also be used to remotely program some alarm parameters on devices in the homes of service users. Such systems normally have a number of additional features and applications which help to provide a more effective service.

It may be apparent that the **technology in the home** of the service user will define the characteristics of the telecare service for that user. In order to ensure that the needs of the service user are met using telecare, it follows that the package of telecare selected for them must be well-matched to their particular needs and circumstances. This is not always straightforward as there exists a diverse client-base for telecare with wide-ranging pathology

and social capital resulting in needs sometimes having to be established using a formal assessment process. Numerous technological devices and solutions exist from various manufacturers to help meet these varied needs, not all of which are compatible with each other, making the equipment selection process even more complex in some cases.

Due to the unpredictable nature of alarms, the **community response** service needs to be available at all times of the day and night throughout the year. Many telecare services rely on informal carers (named key-holders) to provide this community-based response, in fact in some areas of Scotland access to a basic social alarm service is restricted to those who service users who have identified key holders. However, informal carers are not always able to provide a suitable response and, in any case, may not be available to respond when called upon. Likewise, the nature of alarm calls mean that very often it would not be appropriate nor cost-effective to call out the emergency services, who are themselves over-stretched. For this reason and because specialist equipment and training may be required in some circumstances, the availability of a dedicated community-based telecare response team is highly desirable. Team responders require access to all relevant information on clients to which they are required to visit, including the nature of any alarm call; and must also be able to gain swift access to a client's property in the event of an emergency. They require access to a range of equipment necessary to help them deal with a number of scenarios e.g. lifting equipment and automatic external defibrillators. Such teams may be required to provide the *first response* to situations even when an ambulance has been called and so team members should possess suitable first-aid and basic triage skills. Furthermore, they should be suitably trained to recognise when the emergency services might be required to attend.

It may be apparent that robust **operating protocols** are required to ensure that all of the key elements work together and share information efficiently and effectively. These protocols range from the transfer of electronic data between equipment in the home and the monitoring centre to procedural protocols and guidelines for staff that help define how the service should be provided. For example, when a telecare package is agreed upon for a particular individual, it must consist of equipment *and* an individual response protocol which is designed to provide the most appropriate response to need according to the nature of the alarm call, the time of day of the incident and the personal circumstances of the client.

The preceding discussion illustrates that while telecare is enabled via a technological platform, **its successful implementation relies heavily on the actions of skilled and knowledgeable staff within a well-defined and robust operational framework.** These staff are required to perform many key tasks, including: assessing client needs, prescribing the most appropriate telecare package, installing & testing equipment, handling alarm calls and providing a response.

It is apparent that the role of the monitoring centre is pivotal in the successful operation of a telecare service.

2.3 Scotland's Current Call Handling Arrangements

There are 32 local 'partnerships' across Scotland involved in the national Telecare Development Programme as shown in Figure 2.

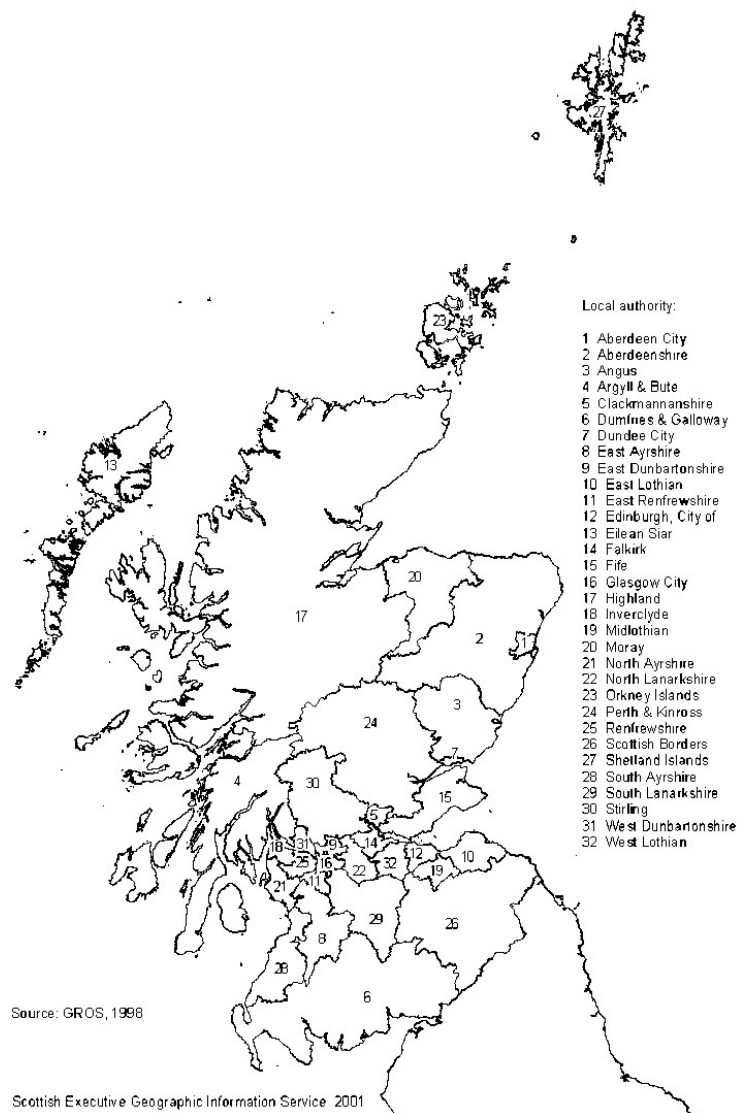

Figure 2. The Scottish Partnerships involved in Telecare.

These include representation from health, social care and housing and each of these is responsible for providing, operating or commissioning a telecare service for their locality; it follows that each will also require the services of a telecare call handling service¹. Such a centre is responsible for handling alarm calls generated from community alarm and telecare

¹ 'Telecare call handling service' is the term preferred by the Joint Improvement Team for Telecare for what is usually referred to as a 'telecare monitoring centre' elsewhere in the UK. It refers specifically to the alarm call-handling role of the centre.

equipment installed in sheltered housing and dispersed homes in the community. Other functions are also performed at most centres (e.g. handling various out of hours calls for council services, CCTV monitoring, general contact centre for council, lone worker monitoring, etc.). The primary role of call handlers is, nevertheless, to establish the true nature of an alarm call and provide reassurance to the service user whilst arranging the most appropriate response.

Some partnerships will operate their own call handling facility; some will share a regional centre with their neighbours, whilst others will prefer to sub-contract/outsourcing this service to a third-party. Recent research by the Joint Improvement Team in Scotland has identified 4 different models of operation within the current provision for call handling services^[1]:

1. Small local centres serving local communities (but which also provide telephone support for other council services such as lone worker protection and out-of-hours reporting of problems with housing, etc.)
2. Medium-sized centres servicing 2 or more neighbouring authorities;
3. Large centres serving large areas of population such as the cities of Glasgow and Edinburgh, and the North Eastern region; and
4. Housing associations which provide services for their own tenants, for some local authorities and for a wider dispersed audience including private payers.

In January 2008, there were 24 telecare call-handling facilities across Scotland^[2]. These are shown in *Appendix 8.1.1* together with their community alarm/telecare alarm receiving equipment. Of these 24 centres, 21 are operated by local authorities, 2 by (national) housing associations, and one by the NHS. It may be observed from these data that there are:

- 16 Tunstall PNC systems (~70% of the market share) - mainly PNC-4 but with a number of older PNC-3 systems. A number of upgrades to PNC-5 are in the process of being completed. Tunstall is the clear market leader both for call handling equipment and for the field equipment for sheltered housing schemes and dispersed properties.
- 4 Chubb Saturn or older Attendo systems (~17% of market share). Chubb is the new name being used for the combined Initial Attendo group when it was taken over by a US security company in 2007. It has nearly 20% of the social alarm and telecare market (including equipment for the home) in Scotland.
- 3 Jontek systems (~13% of market share). Jontek is a specialist developer of call handling and domiciliary care monitoring systems, but does not supply equipment for the home market.

2.4 Drivers for Change

The population of the developed world is ageing rapidly thanks to medical advances but also to a reduced birth rate. Scotland is no different. According to the Registrar General's Annual Review of Demographic Trends for Scotland's Population (2006), the number of people aged 60 and over is predicted to rise by 51% from 1.10 million to 1.66 million between 2004 and 2031^[3]. *Appendix 8.1.2* includes a discussion on changes in the demographic population and on the household composition in Scotland. The data shows that the biggest increase in the population (75%) occurs in those people aged over 75 years. These have been the traditional users of community alarm systems, and are also the target for most telecare services. The implication is that the potential growth of services to meet these demands will be substantial for the next quarter of a century. The other group of people who are considered to be vulnerable in the event of an accident, injury or illness are those who live alone for some or all of the time. As a result of divorce, changes in social structures, and the difference in life-time of men and women, significant increases are expected in the number of people who live alone.

One of the ways in which it is hoped to manage this shortfall in care capacity is to use technologies that are designed to help support independent living. There is clearly a desire on the part of the Scottish Government to facilitate a growth in telecare services. Since 2006, it has promoted telecare service provision through a Telecare Development Programme (TDP) fund of £8.35m. Using this funding, local care partnerships have begun to develop, extend, and mainstream telecare solutions according to the needs and priorities for the local population. It announced in March 2008 that a further 2 years funding of £8m will be available to continue with this programme^[4].

Therefore, demand for telecare and telehealth services are likely to grow as health, care and housing services are re-designed according to a community-based model for health and social care delivery. This is in line with bringing care closer to home and is supported by developments in secondary care including the increasing use of telehealth (supported by a national centre of excellence for telehealth in Aberdeen). Increasing use of technologies including telecare, telehealth and electronic assistive devices are a logical step to try to cope better with the demographic pressures described above and the increasing prevalence of chronic disease (described later in *Section 4.4.3*).

This changing marketplace will influence equipment manufacturers to introduce new and better products that meet the needs of individuals who wish to remain independent in their own homes. Moreover, as digital technologies converge and become increasingly ubiquitous within the home and across the public telecommunications network, new ways of providing these services will be devised. Technological developments will be relevant in three main areas:

- Technology for the home;
- Technology for the monitoring centre; and
- Healthcare informatics and communications technologies – which relate to how information is defined, encoded and transmitted throughout the system from low-level alarm meanings to high-level outcome measures.

The combined effect of the **increasing need to support people in their own homes** (the 'market pull') with the **development of more and better technological solutions** (the 'technology push') will result in telecare solutions that *better* meet the needs of a *greater* number of people. These factors undoubtedly present telecare service providers with an opportunity for growth and have implications for how telecare call-handling services should develop in order to best meet these changes.

2.5 Scope of Report

This report has been commissioned in order to investigate "*the future direction of telecare call handling services in Scotland with regards to changing technologies, expectations and demand*". The work undertaken consisted of desk research and analysis and has considered the likely mixture and scale of services available in Scotland over the next decade, **focusing particularly on the first 5 years**. This is because it becomes increasingly difficult to predict with great confidence the precise changes in technological systems beyond this period but also because new telecare call handling systems have recently been launched by 2 of the 3 main UK suppliers. Thus, it is the functionality provided by these systems that will dominate the next 5 years or so as service providers upgrade their existing systems. A consideration of technological developments beyond this 5 year term has been considered in order to draw attention to future trends. Some of the questions that the report will be considering include:

- What new services might call centres be capable of offering?
- What is the likely timescale for these services to be introduced into the mainstream?
- What is the likely take-up of services?
- What impact will these services have on telecare call-handling services?
- What roles and responsibilities will telecare call handling services assume?
- What will be the implications for call centre staff in terms of capacity, their required skill-set & associated training needs?
- What effect will changing quality standards, outcome agreements, and regulatory approaches have?
- What are the implications of the above (and other factors – e.g. political, regional, economical) for the *structure* of call centres required across Scotland?

3. Technology Drivers

3.1 Introduction

Technological advances often provide the catalyst for changing the way in which services are organised and provided. This has undoubtedly been the case for telecare – a people-oriented service built upon an expanding technological platform necessitating the adoption of new patterns of collaborative working. Significant changes to this platform can therefore modify how services are provided and may enable entirely new service models to be developed altogether. This section will discuss the key technological drivers for change over the next 5 to 10 yearsⁱⁱ in order to establish the likely impact on telehealthcare services with particular emphasis on the monitoring centre.

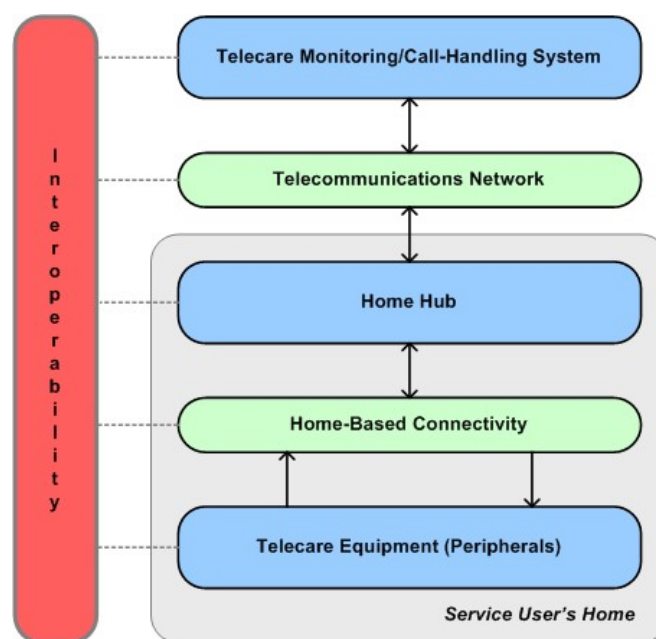

Figure 3. Telecare system architecture.

Figure 3 shows the principal high-level elements of a telecare system from a technological viewpoint. Adopting a 'bottom-up' approach, telecare equipment installed in the home of a service user links into a home hub (care phone), which provides the necessary connectivity to the monitoring centre using the public telecommunications network. For the system to work effectively, there must exist a level of compatibility and interoperability across each of the elements. This is achieved through a number of telecare-related standards and protocols.

Technological developments are currently in progress across each of these system elements and they will, in time, combine to have an effect on how telecare and telehealth (telehealthcare) services evolve. The following sections will discuss each element in turn (issues related to interoperability will be discussed as it applies to each section) and will

ⁱⁱ But mostly focussing on a 5 year period as technological trends become increasingly difficult to predict beyond this period.

conclude with an analysis of the possible impact for telecare services and the monitoring centre and call-handling in particular.

3.2 Telecare Equipment (Peripherals)

An individual telecare package is characterised by the equipment that is installed in the home (usually according to assessed need but also sometimes including elements from a core package). The package will consist of peripherals which, in conjunction with a home hub or care phone, combine to produce the desired telecare applications.

1st generation telecare applications offer significant improvements in performance over community alarms because of their increased use of wireless sensors that alarm automatically to help manage specific identified risks. These are however, in the main, relatively 'low-tech' devices that have been adapted from other applications in a simple manner to be telecare-enabled (usually through the addition of an alarm transmitter). Exceptions include sensors that have been designed specifically for the telecare market and which monitor the individual (rather than the environment) such as fall detectors, bed/chair occupancy monitors and wandering alarms, Table 1.

Table 1. Example 1st generation alarm-based telecare sensors.

Adapted Sensors	Telecare Specific Sensors
<ul style="list-style-type: none"> • Smoke alarm • Flood alarm • Natural gas alarm • Carbon monoxide gas alarm • Epilepsy alarm • Enuresis alarm • Pressure mats 	<ul style="list-style-type: none"> • Temperature Extremes alarm • Fall Detector • Bed occupancy monitor • Wandering Alarm

2nd generation applications such as lifestyle monitoring and telehealth also use sensors to provide data on client activities and vital signs respectively. The former are primarily based on PIR motion detectors developed originally for security applications (with some systems also incorporating other data such as bed/chair occupancy, door use and electrical appliance usage). The latter use standard medical sensing modules which plug into a telehealth monitoring unit, which have themselves evolved from modified clinical units to more compact systems that are better suited to a domestic environment. Their usability has also improved with more intuitive user interfaces including voice prompts and, in some cases, the introduction of wireless connectivity between the sensors and the monitoring unit.

In general, the application of sensors in telecare are focussed around monitoring:

- **The service user** – vital signs, activities, location & identification;
- **The home environment** – temperature, humidity, smoke, gas, etc.; and
- **Interaction of individuals and the home environment** – door use, appliance use, visitors to their homes, etc.

The continued adoption of established technologies to telecare applications together with a number of technological advances across a number of disciplines are likely to have an impact on future telecare applications in the home, including:

- An increasing range of sensors and associated peripherals to choose from capable of supporting an ever-growing range of telecare applications;
- Better integration of technologies into everyday items so that telecare equipment becomes less obtrusive and yet more ubiquitous in the home allowing for continuous non-invasive monitoring. Examples items include: clothing^[5]; other worn items such as watchesⁱⁱⁱ, belts or jewellery; items of furniture such as chairs, beds or baths; and even 'smart' flooring which may be used to monitor activity, detect falls and identify individuals by their gait.
- Technologies such as RFID tagging and optical or image-based techniques to help perform lifestyle monitoring as well as to help identify *who* is performing a particular action (allowing lifestyle monitoring applications to be extended to homes with multiple occupancy);
- Wearable electronics will eventually also extend into the incorporation of buttons, microphones, speakers and even video displays. These technologies are further from market but could, in principle, allow an alarm pendant and communications module to be integrated within clothing allowing alarms to be raised no matter where the individual was inside or outside of the home.
- Power scavenging or harvesting techniques may eventually allow mechanical movement (e.g. body movement or walking), body temperature or solar energy to generate electricity to help power telecare devices so that battery lifetimes can be extended. The burden and cost of battery replacement in telecare is significant so any means of reducing this is highly desirable from the perspective of both the service provider and service user.

The combined effect of these developments will be that sensing technologies will increasingly become integrated into the fabric of the home – so-called 'ambient intelligence' a term coined

ⁱⁱⁱ A watch-based alarm pendant is soon to be launched in the UK (by Tunstall).

to describe the situation where large numbers of small devices situated around a 'smart' home are able to interact in an intelligent way. These devices have three important characteristics: they can be personalised, they are adaptive and they are anticipatory. Thus, in the future, it is likely that telecare and smart home technologies will converge providing an increasingly data-rich environment and extending the options for home automation to help support independence and manage risks. Monitoring and communications capabilities will increasingly be performed on the body allowing data to be collected and alarms to be raised even when individuals are outside of the home.

3.3 Home-Based Connectivity

Connectivity^{iv} within the home is based around the *care phone* which is responsible for accepting alarm signals from peripherals and for initiating actions both externally to the home (e.g. raising an alarm at the monitoring centre) and within the home (e.g. activating visual/audible beacons or generating messages for a pager).

Alarm signals are received by the care phone either via a wired input or, more commonly, by radio. Typically, a care phone might have only one wired input but can receive alarms from numerous wireless devices in the home. Wireless alarm signals are conveyed to the care phone using proprietary protocols operating on one of a number of standard radio frequencies (depending on the manufacturer, model and age of the care phone in use). The wireless link is uni-directional^v and the messaging protocol used is normally not designed to convey complex information or standard data types.

Care phones can perform actions in the local environment by using a switched relay output or by using an X-10 module to control mains-powered lighting and appliances (e.g. to fade lights up to help prevent a fall when an individual gets out of bed to visit the bathroom during the night or to turn off the television during an alarm call so that the sound of the television does not interfere with the conversation between the service user and the call-handler).

The lack of a common messaging protocol means that interoperability between devices and care phones from different suppliers is not always guaranteed. This can frustrate the process of building the best possible package of equipment to meet the particular needs of an individual and can mean that best of breed products cannot always be selected. Pressure from service users, providers and commissioners together with technological advancements will increasingly see plug and play interoperability between all telehealthcare devices. Improved

^{iv} within the context of this report, connectivity relates both to the physical and logical (or information based) interaction between devices within the home.

^v i.e. information is transmitted wirelessly from the trigger/sensor to the care phone only.

connectivity options in the home may include radio-based technologies using Bluetooth, Zigbee and RFID (refer to *Appendix 8.2.1*).

However, as well as being able to *communicate* with each other (by adopting compatible wireless technologies and operational frameworks), devices must also be able to *understand* each other. This requires the adoption of common data types, terminology and messaging protocols. This is one of the goals of the Continua Health Alliance - an industry-based collaboration that exists to help standardise the way information is coded and shared between healthcare-based entities and equipment from different vendors^[6]. It includes many well-known semiconductor, healthcare and domestic appliance manufacturers and includes Tunstall and Tynetec from the UK telecare supply sector. Several of its members are working on plug and play interoperability standards for telecare-type equipment in the home. Based on the IEEE 11073 standards, they will define a common core of communication functionality for devices that communicate with home care hubs with initial work focussing on a number of common binary-state devices including: fall detectors, bed/chair occupancy sensors, motion sensors and pendant triggers.

Whilst it may take several years for the benefits of this process of standardisation to appear in the marketplace, it will eventually help remove some of the obstacles for interoperability that currently frustrate service providers.

3.4 Home-Hub

The home-hub is the central receiver and processor unit for telecare in the home and also provides a connection to the monitoring centre call-handling system via the telecommunications network. With 1st generation alarm-based telecare, the 'care phone' performs these functions, though few modern units look like a telephone nor do they have a handset and a keypad. Currently, separate units are required to support 2nd generation applications such as *lifestyle monitoring* (which requires additional data-logging capacity) and *telehealth* applications (which requires specialist processing circuitry and may include a user-interface for allowing users to fill out a personalised health survey). Both require a modem to transmit higher volumes of data than is required for alarm-based applications.

In summary, the role of the home hub (or equivalent) is to:

1. Accept signals/data from devices in the home;
2. Provide some means of controlling elements in the home (currently very limited – but there is some use of X-10 mains based signalling to switch lights in the home);
3. Perform some level of processing (which could be as simple as establishing which alarm code to transmit on to the monitoring centre);
4. Store data locally for lifestyle monitoring applications (where applicable);

5. Offer connection to the public telecommunications network and transmit alarm and data information onwards and receive commands and data from the monitoring centre system;
6. Provide a two-way speech capability with the designated responder (normally the Telecare Monitoring Centre);
7. Provide a user-interface to the service user;

Most existing care phones are relatively 'dumb' but as the sensing environment becomes richer and connectivity options within the home become more sophisticated, there will be a drive to improve the data-storage capacity and intelligence available within the home hub to enable more advanced applications. This evolution of the care phone can already be observed in the marketplace; for example, the Tynetec Sayphone 21 includes a memory card for data logging and a modem to allow remote access to data for lifestyle monitoring applications. These principles have been extended by Tunstall's new 'Connect+' home unit which, in addition to facilitating data logging and transfer for use with their ADLife lifestyle monitoring application, also claims to support a number of virtual sensors including:

- Virtual Bed/Chair;
- Inactive Client Sensors; and
- Virtual Property Exit Sensor (PES).

Virtual sensors are software-based algorithms or logic that accept inputs from a combination of physical sensors distributed throughout the home. For example, a 'virtual' property exit sensor might be created by combining the inputs from a PIR situated inside the hallway with a door-status sensor. Because the sensor is virtual and hosted on the care phone, it is now possible for monitoring centre staff to remotely re-configure alarm parameters such as the time before an alarm is raised. This functionality is particularly useful in reducing incidents of false alarms. Moreover, it means that a visit to the property is no longer necessary which means that there is less disruption to the service user and a more responsive and cost-effective solution for service providers, particularly in rural areas.

Appendix 8.2.2 describes further developments likely for the home-hub of the future.

3.5 Telecommunications Network

Telecare systems transmit alarm information from the care phone in the home to the monitoring centre over the Public Switched Telephone Network (PSTN). In some circumstances, where a landline is not available (for example if the bill has not been paid) it may be possible to use the mobile phone (GSM) network.

British Telecom (BT) is currently undertaking a massive overhaul of its core telecommunications infrastructure, dubbed the 21st Century Network (21CN) - implementing a new IP-based digital network across the whole of the UK, based on faster ADSL2+ technology (which has a maximum download speed of ~ 24Mbit/s – although this is unlikely to be achieved in practice)^[7]. The roll-out of 21CN started in November 2006 and BT expects that 50% of its national customer base will have migrated by the end of 2008 with the roll-out completed by the end of 2011. Some older care phones, warden call systems, security diallers, fax machines, and communication protocols have been shown to be incompatible with the new system following consumer equipment testing by BT. **As a consequence, alarm activation from older telecare equipment may not raise an alarm at the monitoring centre.**

3.6 Telecare Monitoring & Call-Handling Systems

Alarms generated by telecare field equipment are normally^{vi} forwarded to a telecare monitoring & call-handling system situated in a Telecare Monitoring Centre (TMC). The call-handling system allocates the call to an available call-handler together with details of the service user and the reason for the alarm call. A two-way speech channel between the call-handler and the home of the service user is then established. In addition to processing alarm calls, call-handling systems usually allow an operator to remotely setup care phones (e.g. to programme a new device into its memory prior to installation).

The Telecare Monitoring Centre is often considered to be the hub of a telecare service, acting effectively as an intelligent switch, distributing requests for help to the most appropriate responder or service provider according to a set of pre-defined protocols (although telecare call-handlers are usually able to handle most calls themselves). The current focus of monitoring centres is handling alarm calls generated by community alarm and 1st generation telecare equipment installed in schemes and in dispersed properties.

Traditionally, there have been three providers of monitoring centre equipment and software for the telecare market in the UK, namely: Tunstall (~ 70% market share in Scotland), Chubb Community Care (~17%) and Jontek (~13%). The latter is perhaps unique in the sense that Jontek do not produce their own equipment for the home and are therefore in a sense considered to be 'independent'. However, until a genuine open standard for telecare alarm protocols is adopted by the industry, it will always be dominated by the market leader who also happens to make its own telecare monitoring & call-handling system.

The protocol used to convey alarm information between the care phone and the monitoring centre is often proprietary and linked to the manufacturer of the care phone (e.g. Tunstall TT-New/TT92/TT21, Bosch, etc.). A British Standard (BS 7369) has been in existence for a

^{vi} Alarms can be directed to an informal carer in the first instance, if desired.

number of years, although it suffers from limited functionality resulting in it being unsuitable for use within modern telecare systems. It has also been shown to be incompatible with the new 21CN telecommunications network planned for the UK, and has consequently been declared obsolete. An enhanced protocol is being developed to address these limitations and is currently in the long process of being considered as a British Standard (BS 8521). It remains to be seen whether this new standard will be robust enough or sufficiently future-proofed for it to be adopted as a legitimate protocol for modern telecare applications. It is likely that some manufacturers (with the lion's share of the market in the UK) will continue to promote their own protocols – particularly if they offer enhanced functionality over standardised variants and especially if this functionality can only be accessed by using their own monitoring centre software.

The Telecare Monitoring Centre is a critical element of a telecare system for enabling support or assistance to be provided to vulnerable people in a timely manner. It has to be available and staffed at all times, night and day, and must operate with close to 100% reliability in handling events which may be of an increasingly life-critical nature as the dependency of service users moves towards the critical and substantive levels of need and risk. This makes it not only "mission-critical", but also an expensive component of the telehealthcare service. Any spare call-handling capacity is often used to provide other telephony-based call-centre services. The expansion of telecare and telehealth technologies in the home is likely to extend this role both in the short- and medium to long-term. The services provided by a TMC will therefore vary and can, or might in the future, include:

- Telephony-based services (which may include video-based telephony) such as:
 - Handling 'out of hours' calls for external agencies (e.g. council);
 - Incoming non-alarm calls (e.g. pendant-triggered) for a chat/reassurance;
 - Proactive calling – to check up on service user ranging from birthday/courtesy calls through to health survey questionnaire;
 - Proxy-based support/advocacy;
 - Providing help and assistance with equipment, etc.;
 - Processing self-referrals;
- Alarm-handling services:
 - Manual alarms;
 - Telecare sensors;
 - Security diallers;
- Alert-handling services:

- Lifestyle monitoring – non-clinical triage;
- Telehealth – non-clinical triage; clinical triage; health coaching
- Lifestyle monitoring data analysis for assessment purposes;
- Access management – storage of keys, management of key-safe access codes, remote access;
- Lone worker protection;
- Home care monitoring;
- Person location/tracking;
- Remote programming of field equipment;
- Data management:
 - Equipment asset management & maintenance;
 - Performance review/management reporting;
 - Telecare customer database & relations management;

It may be apparent that a considerable IT resource is required to host all of these services. At present, many are supported using entirely separate platforms, although there is some level of integration across a number of areas (e.g. many telecare call-handling systems provide support for security diallers, lone workers and home care monitoring). However, the ultimate goal must be to have all of these services supported over a single telecommunications infrastructure which integrates seamlessly with an integrated call-handling application. The move towards an IP-based telecommunications network will help to achieve the former, but the latter will depend on the adoption of open/standardised protocols or the genuine sharing of proprietary protocols. Features that are becoming or will become increasingly popular for telecare-based call-handling platforms are listed in Table 2.

Table 2. Features of a modern telecare monitoring & call-handling platform.

Feature	Examples / Description
Video-based functionality	Video-based services can include: video telephony for face-to-face reassurance or for providing assistance; video on demand distribution of educational / instructional videos; and access management – confirming the identity of a visitor prior to allowing access remotely
Skills-based routing	The expansion in services that are likely to be available in a monitoring centre means that call-handling staff may need to specialise in particular areas such as telehealth or lifestyle monitoring or in particular client groups such as people with dementia or learning difficulties. Therefore a call handling system that is able to route incoming calls based on the client's known history and on the nature of the alarm call to the most appropriate (and available) call handler is beneficial. This can also be extended to include issues such as language as well as distributing calls to different call centres based on the type of services offered.

Feature	Examples / Description
GPS/Mapping Integration	Systems that integrate GPS information with mapping software so that the operator is able to find an individual (e.g. a client who is wandering) or transfer information to a mobile response team so that they may readily locate a property and even using the information to identify the closest responder to the property to ensure a prompt response.
Mobile alarms	The ability to accept and process alarms from mobile-based social alarms.
Interactive Voice Response (IVR) systems	For automating a number of telephony-based monitoring services such proactive monitoring of medical parameters or health surveys.
Proactive calling assessment scripts	Automated computerised scripts for managing health surveys for proactive calling applications.
Call Transfer	Being able to transfer a call to another call handler or third-party service provider such as a mental health helpline.
Call conferencing	Allows an operator to connect calls between multiple parties. For example to connect a service user with a contact or to obtain assistance from a language translation/support service.
Remote programming of field equipment	This is important for alarm-based telecare applications and may become increasingly important as virtual sensors become more commonplace. It is likely to extend to lifestyle monitoring and even telehealth applications. It is particularly useful in rural areas where the need to visit an individual in a remote area to alter a single parameter on a sensor that is not setup correctly can be inefficient and costly. This is likely to be the case in large areas of Scotland.
Remote upgrading of field equipment	As care phones evolve into care hubs, there will be more scope for upgrading the functionality of the units whilst in-situ.
Database consolidation	Two or more monitoring centres can use the same database and share the responsibility of call handling or implement reciprocal disaster recovery arrangements.
Distributed working/'Virtual' call centres	Allows the call handling infrastructure to be extended beyond the monitoring centre which enables more flexible working arrangements such as home working.
3rd party application launching & integration	The ability to launch third party software applications and pass data onto them in order to obtain additional functionality that is not in-built into the monitoring platform.
Systems integration	The integration or information sharing between disparate database systems such as home care, social work care records, single shared assessment, NHS health records, Ambulance service, NHS-24, etc. This requires common information standards such as HL-7 but also common XML messaging standards to stream data between applications/databases.
Automatic reporting capabilities	This is particularly important as the pressure to prove service efficacy through continuous performance review and evaluation increases. An important part of establishing how a system is being used is to analyse the type, frequency and distribution over time of alarm calls. It also includes analysing alarm types, actions and outcomes and often needs to consider other factors such as details of care packages in order to show the impact of the telehealthcare-based intervention.

Tunstall and Jontek have recently introduced new variants of their telecare call-handling software – the PNC-5 and the Answer-Link 3G respectively. These platforms are beginning to offer the more advanced functionality required from a modern telecare call-handling platform although the complete integration of services is still patchy. The PNC-5 supports the new TT21 communications protocol that is necessary to support a host of new functionality in their new

Connect+ care phone. It is difficult to imagine that Tunstall would be willing to open this protocol up to competitor systems.

The lack of application integration within call-handling platforms is likely to change in time, however, as a result of a general shift towards IP-based technologies and the use of standardised protocols and data modelling techniques. Early examples of this next-generation of monitoring centre platform that happen to support telehealthcare applications include the Verklizan (Novalarm) UMO care centre and the MediaGrids CareMate ONLINE. Both claim the potential for compatibility with telecare devices from multiple vendors but it may be that truly independent cross-platform monitoring centre applications will struggle to achieve 100% compatibility until open standards are agreed across the whole telehealthcare industry. Certainly claims for compatibility are challenged by some of the leading vendors of telecare equipment for the home.

3.7 Key Points

Whilst some of the technologies discussed in this section may be some time from market, it is clear that the trend in home-based telehealthcare is towards a data-rich pervasive sensing environment that incorporates both the home and the person. This will improve both the availability and quality of data available (and hence reduce uncertainty about client well-being) as well as enable the detection of intermittent patterns (e.g. cardiac arrhythmias).

The implications for call handling are that in the future, there will be a greater range and variety of sensors spanning a broader number of applications, and for which different roles and response protocols will need to be established. It also means that the limitations of previous generations of sensors (in terms of appearance and functionality) will disappear, so the acceptance of telecare amongst the public will improve rapidly in-line with an increasingly technology-savvy population.

To summarise, the majority of the telecare technologies and systems *in use today* may be characterised as follows:

- **They are alarm-based and event-driven** – each call to the monitoring centre is treated as an alarm. The call is triggered by a discrete event that either involves the service user manually raising an alarm or a sensor doing so automatically.
- **The volume of data transmitted from the home is small, infrequent and transmitted over a narrow-band 'on-demand' connection** – due to the event-based nature of the system, only a very small amount of data needs to be transmitted to the monitoring centre;
- **The number of alarm calls that require a physical response is low** – The number of 'false alarms' or non-emergency calls is high. This is either due to

manual calls, test calls, or faulty/incorrectly setup equipment.

- **There are low levels of system integration and intelligence** – elements installed in the home are not generally capable of working together either to more accurately determine alarm conditions by combining information or by controlling aspects of the local environment in order to help manage risk.
- **Open standards for connectivity and interoperability in telecare are either not fit for purpose or non-existent** - the lack of standards means that there are limitations in how much equipment from different vendors can be combined both within the home environment and in conjunction with monitoring centre equipment
- **The integration of different applications at the monitoring centre onto a single technological platform can be difficult or non-existent** – a lack of application integration and standards means that services must sometimes be operated using different systems.

The preceding discussion has highlighted a number of technological developments, which are likely to have an impact on how telecare systems in Scotland are realised over the next 5 – 10 years. Moving forward, the likely effect on call-handling arrangements are not always straightforward to determine but systems will become increasingly characterised as follows:

- There will be more devices in the homes of service users (and located on their person);
- There will be an increase in the scope and quantity of data originating from the home due to the increased sensing capacity caused by an increase in the number of sensors available and a shift towards sensors that generate data as well as alarms;
- There will be a greater number of detectable alarm conditions;
- Improved connectivity in the home will allow more intelligent behaviour to be performed by the system in the home – thus helping to manage more risks and to prevent certain alarms from occurring in the first place (a genuinely preventative service);
- Improved interoperability between equipment from different manufacturers will allow a mix and match approach to equipment selection to be adopted allowing best-of-breed solutions to be incorporated into a telecare package irrespective of the manufacturer;
- As more 'intelligent' care phones are introduced, the system in the home will exhibit increasing capacity for '*dynamic configurability*' allowing its functionality to adapt to the changing needs and circumstances of the individual being monitored. This configuration will be possible using monitoring centre systems, allowing monitoring centre personnel to *remotely* change system parameters, e.g. to reduce

the number of false alerts and/or enable or disable alarm functionality by modifying alarm thresholds and settings. This avoids the need for a visit to the home, which can be expensive, inefficient, and potentially disruptive. This functionality will eventually extend to individual sensors when *bi-directional* communications are available in the home.

- The move towards IP-based systems and common protocols will provide the conditions necessary to enable a more versatile integrated platform on which to provide telehealthcare and related services.
- There will be a convergence of telehealthcare applications (alarm-based telecare, lifestyle monitoring, telehealth) onto the same platform, ensuring that sensors installed in the home can operate in mixed modes and alerts can be generated in real-time at the monitoring centre.
- Monitoring centres will have to host, process and analyse data in addition to traditional alarm call-handling. This data will consist of behavioural events, physiological data and answers to well-being questionnaires. This data will require different methods of processing depending on the application but will certainly require the development of new operating protocols and inter-service partnerships in Scotland. New staff roles may be required to perform non-clinical triage on the data sets and alerts generated by systems to filter out significant events and to handle other alerts themselves (there may be in the short to medium term may a high number of false alarms due to insufficient system knowledge (sensors) and system intelligence).
- There are likely to be technical issues which need addressing locally if data is to be hosted at the monitoring centre (data security, access, protection, backup) or as part of a Service Level Agreement if hosted by a third party.

Whilst there may be a considerable attraction in moving quickly towards more futuristic platforms, such a move could be extremely risky when existing provision depends so much on the old social alarm infrastructure. There is a significant investment in telecare technology in Scotland and Partnerships simply cannot afford to upgrade all equipment at the same time (nor is this a practicable proposition). There must then be a commitment from manufacturers to consider legacy issues, and this is the case amongst current providers. However, supporting legacy systems can act as a barrier to progression. From the technology provider perspective, it may stifle innovation and may cause the organisation to lose its competitive edge. Certainly, rival organisations may take the opportunity of leaping ahead with their latest propositions but, to date, this hasn't happened to any great degree and product development follows a more predictable path.

It remains likely, therefore, that only gradual changes will be technically feasible until there is either a universal adoption of an IP based system, or complete interoperability is proved. The

time-frame for these changes is likely to be 3 to 5 years even though the technologies are already available.

Naturally, there will be associated training implications for all the above that will be considered in *Section 5.3.2*.

4. Call-Handling Services

This section discusses the implications of changing technologies, expectations and demands on call-handling services in Scotland.

4.1 Basic Community Alarm Services – Introductory Telecare

Many social alarm services managed by Scottish local authorities are distinguished by the extent to which social work departments were instrumental in their establishment. This is despite sharing their origins (as in the remainder of Great Britain) in sheltered housing. Future trends might therefore depend on how sheltered and newer housing with care models evolve, and receive funding. In particular, the role of housing associations and the NHS Scotland are becoming significant in providing more support in the wider community for people to receive care at home.

The earliest social alarm services in Scotland were those in East Lothian and in the Central Regional Councils, both social work rather than housing authorities. The former service commenced in 1979, serving the City of Edinburgh but with some funding from the Lothian Health Board. It was not intended to give cover to sheltered housing schemes managed by the council, but to focus on the needs of other groups, and in particular those of older people in the wider community. Management was later vested in a monitoring and response centre facility operated jointly with Midlothian Council. The Central Regional Council service was set up in 1980 with the monitoring and response centre located at a hospital in Larbert showing the interest and financial support of the Local Health Board. For a fuller account, please see "Social Alarm to Telecare" by Malcolm Fisk, Policy Press (2003). By 1996, of the 17 full-time monitoring and response centres operating in Scotland, 10 were operated by the social work departments of the authorities involved, with a sizeable minority run by housing departments or housing associations. This is consistent with a conclusion that over 60% of end users were in dispersed properties using care phones (or home telephone interface units) with a minority using alarm systems in sheltered housing schemes.

By today, there are nearly 130,000 social alarm/telecare users known to the 32 local authorities with up to 50,000 others (mainly tenants of RSLs) connected to services operated by Hanover (Scotland) or Bield Housing Associations i.e. a total of 180,000 service users. The percentage penetration ranges from 43% of those aged over 65 years in Stirling down to only

9% in Argyll and Bute but with the majority in the range 20 to 30%^[8]. The factors which might most influence the future take-up of social alarms are:

- The future growth or decline of sheltered housing and other extra Care/Housing with Care Models;
- Supporting People funding for some people;
- The introduction of telecare as a preferred alternative to basic community alarms;
- The use of mobile phones (including mobile care phones); and
- The likely percentage penetration possible.
- Charging Policies and the eligibility criteria adopted for community services

4.1.1 Sheltered Housing

The number of sheltered housing units in the UK and Scotland peaked during the 1980s. Since that time, the demand has dropped significantly and most local authorities and housing associations report voids, especially in inner-city schemes and where only bed-sits are available. All sheltered units must be provided with a warden call system, or some method which allows people to access support on a 24 hour basis. This was the origin of the community alarm. Any reduction in the number of sheltered housing units will automatically reduce the number of community alarm users though the reduction may not be proportionate due to other forms of provision. In practice, because the alarms are part of the properties, the number of users in the statistics may include those properties which are void, as well as the provision of alarms in properties that are now used for general needs. Thus, it is possible that the number of users of community alarms is already an over-estimate.

A full analysis of changes that are likely with respect to sheltered housing provision is given in Appendix XXX. It suggests that the number of community alarm users might reduce by about 10,000 over the next decade..

4.1.2 Supporting People

This funding stream provides housing based support for vulnerable people, including those people who are aged over 65 who represent nearly half those receiving services funded via Supporting People. In principle, it can be offered to people irrespective of their tenure and type of accommodation, and support is split fairly equally between people in mainstream housing and those in other types of housing including sheltered housing (25%). 36% of recipients are estimated to receive floating support at a level of 1 to 4 hours per week from a warden-type service while an estimated 30% have permanent support in the form of alarm systems for example. The number of clients receiving housing support in 2004/5 was nearly 57,000. This fell to under 41,000 by 2005/6 suggesting that fewer people were receiving a higher level of support^[9] though funding for their services might have been transferred to Social Work.

The total funding available through Supporting People may not have originally been sufficient, and it certainly has not been increasing in line with demand and with inflationary pressures. Commissioners are therefore looking to achieve improved value for money by driving down core costs wherever appropriate. This is already having an impact in England where the charges for the alarm monitoring element of support are being reduced, often by concentrating the activity through one monitoring centre in a region in order to increase efficiency.

It is possible that some local authorities may in future limit the number of people in dispersed settings who are eligible for Supporting People subsidy for their social alarms in order to focus increasingly on the needs of people who are more vulnerable; it should, however, be noted that *not all LAs use SP to fund their alarm provision*. It is possible, nevertheless, that a focus on more vulnerable people may increase the number of people on telecare but decrease the numbers receiving a community alarm service. Overall, it is possible that the effects of reduced funding (in real terms) and the shift to fund telecare may involve a 20% reduction in numbers receiving CAS over 10 years.

4.1.3 Advanced Telecare to Replace Introductory Telecare

The role of social alarms has generally been considered to be one of prevention in that it helps vulnerable people to gain access to services earlier thus leading to better outcomes. Telecare offers even more rapid detection of specific emergency situations and, furthermore, by having response protocols already available, ensures that the optimum arrangement is in place for dealing with that situation without resorting to using the emergency services. Few organisations have in place strategies to promote the use of social alarms whereas all have set themselves targets for telecare. The average time that someone in the community has a dispersed social alarm was a little over 5 years according to 3 CUHTec member organisations and service providers surveyed in 2006. It means that around 20% of connections turnover every year and are potentially lost. Most authorities aim to replace these customers with new service users and succeed in maintaining their existing complement while recycling the equipment.

In the future, with human resources concentrating on increasing the number of people with more advanced telecare systems there may be an inevitable decline in the recruitment of people with introductory telecare systems. Indeed, many local authorities in England and Wales (e.g. Leeds and Gwynedd) are taking the opportunity of including at least one peripheral device (such as a linked smoke detector) as well as a key-safe within their introductory telecare packages. A consequence of such actions could be that the rate of new social alarm renewals (i.e. introductory telecare) is halved. This would result in a 10% drop in connections every year though many of these service users would receive a more advanced telecare package instead. Nevertheless, because the cost of equipment for introductory telecare may

be anything from 50% to 100% more expensive than the care-phone and pendant alone, this could lead to an overall reduction of between 2 and 3% every year.

It should be noted that tenants in sheltered housing would not be affected by such changes because the alarm system is a required component of their tenancy. However, the introduction of BT21CN may also force many housing associations and local authority to upgrade their systems in order to ensure that their alarm systems are fully functional in the future. Organisations may have their own strategies to deal with 21CN but in South Wales, where the process first began, there is evidence from the Vale of Glamorgan of hard-wired schemes being replaced by individual care-phones. This council has also decided to offer a telecare safety package (including 2 smoke detectors and a temperature extremes device) as its basic telecare offering, expecting a small reduction in total customers over the next 2 years.

4.1.4 The Use of Mobile Phones

There is no shortage of data to show that currently older people are less likely to own and to use mobile phones than younger people. The Continuous Household Survey results from 1999 to 2006 (Figure 4) show a near ten-fold increase in ownership by people aged 60 and over compared with a tripling of use by the general population during the same period. Ownership by females in the 16-19 age group reached 98% in 2006 and saturation is likely in other groups over the next few years^[10].

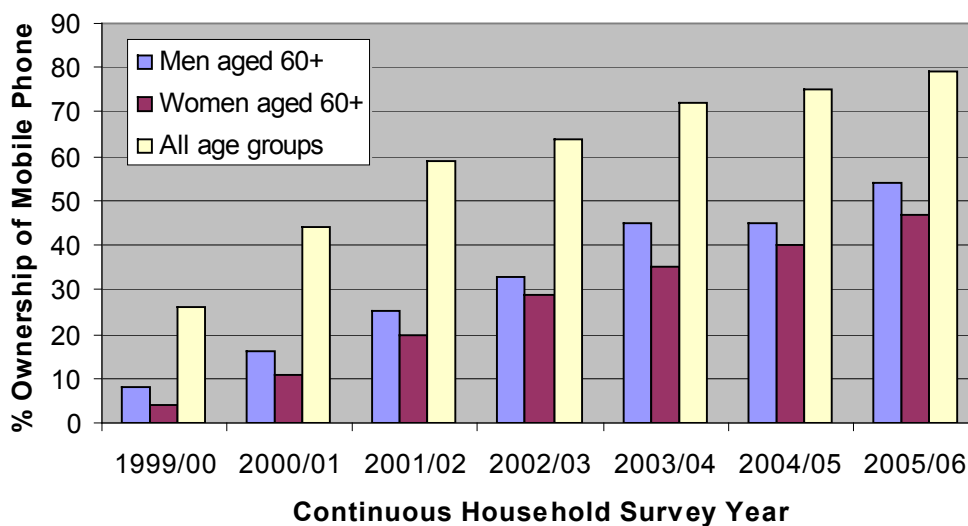

Figure 4. Ownership of mobile phones in the UK.

It follows that more than half of older people already own a mobile phone, and the percentage will increase in the future as:

- People who already have phones turn 60;
- Low cost ownership and use schemes ("Pay as You Go") are extended; and
- New phones appear which have fewer functions and which are easier to use.

Appendix 8.3.1 describes a number of new mobile phones that are now available to overcome the limitations described above.

Whilst the number of older and vulnerable people who own and use a mobile telephone will undoubtedly increase in the future, it will only impact social alarm use if they abandon their fixed lines in order to do so. Unfortunately, this is what may be happening. People who use their telephones relatively infrequently for outgoing calls, often feel that they are being charged inappropriately for line rental and service. Rather than paying two bills, they are therefore likely to opt only for their mobiles – even though individual calls may be higher. It is likely that many people may be convinced that their mobile can perform the same functions for them as their social alarm. In terms of making an emergency call, this is certainly possible, but mobiles need to be charged overnight (when many social emergencies occur) and are too large to be carried around the house. They are also not water-proof and are therefore unsuitable for use in the bathroom. This possibility is being addressed through the launch of mobile social alarms throughout Europe. These devices have GPS capability and can therefore also be used for locating someone when they have a problem. The Gsat system currently available from Maplin stores is a low cost example of such a telephone, but many others are available from the major telecare distributors.

The above problem is likely to be mitigated by the need for a fixed line in order to use Sky TV and for ADSL services for fast internet access. It is possible that some Freeview boxes may also require a fixed telephone line for interactive services in the future. However, as 3G mobile services are accessible by increasing numbers of people, it is likely that wireless arrangements will be put in place to avoid the need for a fixed line. It remains likely that introductory telecare systems will, in the future, need to compete with mobile phone systems that may bypass the current alarm call handling centres. Because mobile technologies may not yet link with telecare sensors, the threat may be most relevant for people in the 60 to 75 age group and who may not have appreciated the benefits of a managing risk through sensors.

4.1.5 The Penetration Potential

There are significant variations in the level of social alarm use amongst older people in Scotland. The distribution across the Scottish partnerships is shown in Figure 5. It is a normal distribution with a mean of 25%^[11].

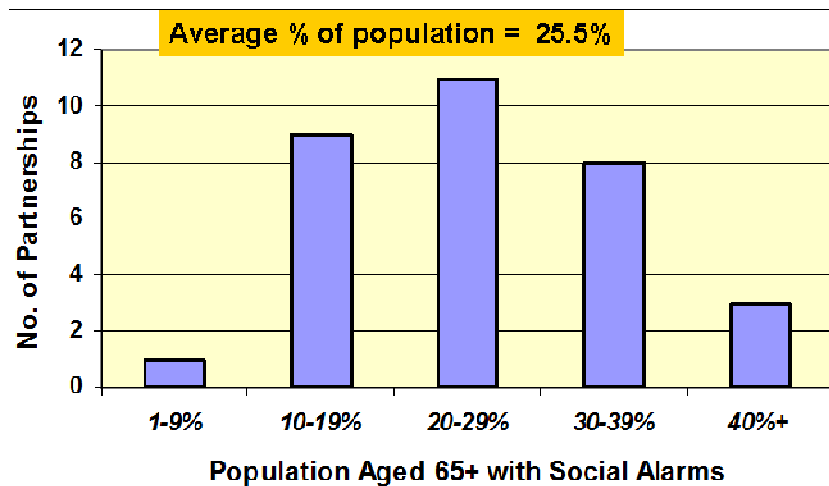

Figure 5. Penetration of Social Alarms in Scottish Partnership Areas.

However, the fact that three areas (Stirling, Falkirk and North Lanarkshire) can achieve 40% or over penetration in this market implies significant success in service promotion or a significantly different charging policy. In terms of actual numbers of connected customers, one of these areas is in each of the three higher number bands shown in Figure 6.

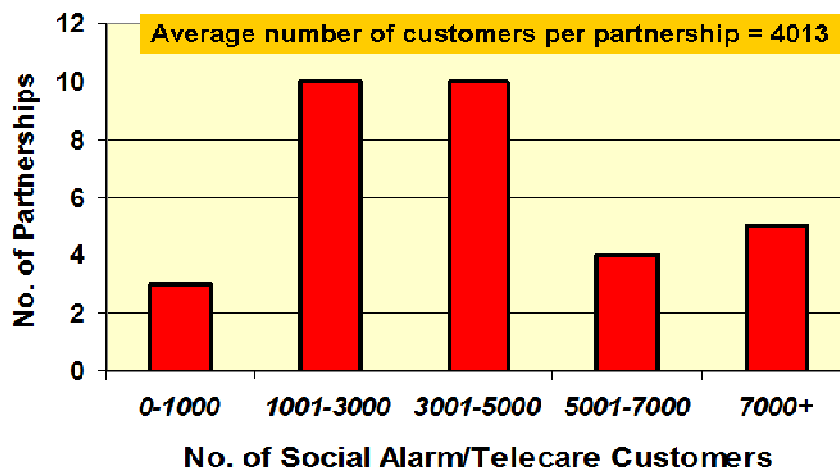

Figure 6. The Number of Social Alarm Connections for Scottish Partnerships.

This implies that high percentages can be reached irrespective of the pool of older people available; it may be reasonable therefore to assume that the most relevant factor is local strategy which includes cost and the ease with which the service may be accessed.

4.1.6 Overall Impact

The impact of possible changes in actual numbers of customers on call-handling requirements may not be as significant as the percentages might imply. This is because many calls currently made through the system may not be classed as social emergencies. They might, for example, involve the reporting of issues of a housing nature, including faults and complaints about the behaviour of neighbours or youths. What constitutes an emergency is still an issue for debate, and there is little agreement between providers on many types of incident. What is clear is that there is no simple relationship between the number of calls received and the number of

service users with access, Many people choose to deny that they have a problem for a long period of time; this is consistent with people waiting an average of 90 minutes before calling an ambulance in the event of a suspected heart attack (Professor Peter Weissberg, British Heart Foundation, 2007).

However, if social alarm users are not replaced by telecare users then it will have an effect on strategies for charging, for system renewal and, ultimately, on the average cost per customer of providing a service. It will inevitably mean fewer calls where the support needed is rather different to the usual connection to family or emergency services. More of the calls will be genuine emergencies, though many of them will not require the traditional emergency services. The importance of having agreed response protocols in place will be paramount, as will the handling of these calls at the monitoring centre. Training methods will need to improve to cover the breadth of support needs, together with more options for transferring calls on to other call centres – and, ultimately, to more dedicated help-lines. Many of these may be provided by charities and are likely to include a raft of different support mechanisms for people with mental health problems including related issues of obesity, anorexia, drug or alcohol abuse and smoking cessation. Figure 7 shows a plethora of such services that are now available. It follows that call handling staff will need to know exactly which services are suitable and when they are available for referring on appropriate customers. Few examples of such links currently exist.



Figure 7. A variety of help-lines are available.

In summary, the greatest threat to existing social alarm centres may be the future domination of mobile connections where the operators choose to ignore the local telecare infrastructure and use their own national (or international) support desk which may be offshore and which might employ staff who have no knowledge of social care issues. 93% of households now have

a mobile connection compared with 90% with a fixed line. One third of all phone calls are now made on a mobile^[12].

4.2 Extended Alarm-Based Telecare

Extended 1st generation alarm-based telecare represent the mainstay of telecare provision in the UK and has been used in the vast majority of successful telecare implementations to date with or without stand-alone equipment. The sensors are prescribed to manage identified risks to the service user and cover a range of applications from environmental and security alerts (such as fire and intruder alarms) through problems of a social nature (including falls and incidences of poor nutrition or coping). The infra-structure for this form of telecare is precisely that offered through a modern social alarm system, which is partly why it has dominated early telecare systems.

A number of existing sensing solutions are likely to be improved upon in order to meet shortcomings, including fall detectors (which can be prone to false alarms and wearability issues) and a genuine programmable hypothermia alarm that can be set according to the circumstances of the individual rather than designed to protect the property from flooding due to freezing pipes although there are wider environmental benefits of such sensors including the detection of a heating failure or of a door or window that has been left open unintentionally. Further examples of improvements in sensor technology are described in *Appendix 8.3.2*.

The speed with which new sensors will appear within telecare systems will depend on the way that the market evolves and, in particular, the acceptance of new working practices by health trusts and boards with an increased focus on 24-hour support services. No government agency has published guidelines on these applications though the examples offered in various documents demonstrate an official acceptance of the evolving nature of the technology and how new sensors may be used to reduce the need for unscheduled care in hospitals. The emergence of response services with medical team involvement will see a rapid expansion in demand for these technologies.

4.2.1 Implications for Call Handling

Generally any new alarm-based device will have minimal impact on the monitoring centre as it is built around an alarm-based infrastructure. Some devices will require more complex response protocols than others (e.g. automatic gas shut-off solutions and hypothermia alarms). New alarm-based sensors allow services to be offered to more people resulting in service growth. With medical alarms, there is a need to ensure that response protocols are optimised to provide a rapid response by the most appropriate teams.

However, with the emergence of each additional device, the potential for more administrative work in establishing and noting response protocols increases, as does the need for staff to understand the purpose of the device and the need for sensitive call handling both in the event

of an emergency, and when batteries need to be replaced. Despite the current low rate of increase in the number of new peripheral devices, it is possible that 3 or 4 innovations will appear every year resulting in a doubling of the sensor inventories within 5 years assuming that there are currently between 15 and 20 peripheral devices currently available. If a monitoring centre is employed as the location for cleansing, testing and recycling equipment, or if it is used as a general store for peripherals, then the required area may also be expected to double every 5 years as will the capacity to accept more referrals, perform more assessments, prescriptions and installations.

The risk of new sensor devices being triggered at similar times of day or night as existing sensors is extremely low as many of the ideas described above are appropriate to nights, for example, when activities that might lead to other alerts (such as fire and flood) are less likely. The result could be that the peaks and troughs of alarm calls are spread out. This means that staffing levels may need to be adjusted in order to achieve a rapid response at all times. New devices are also more likely to be smart and have built-in self-test capabilities. A result may be that sensor failures will be reported whenever they are prepared for action. In the case of a nocturnal incontinence detection system, this is likely to be during the evening or as people retire for the night. This might result in minor surges of activity during periods of the day or night which previously weren't busy. Current shift patterns may need to change in line with emerging demand patterns.

4.2.2 Summary

Increasing numbers of complex telecare alarm packages are inevitable as both the technology (including the choice of sensors) and the evidence for service success improve. The people receiving these package will be frailer and considerable less able than individual currently using community alarms or introductory telecare packages. They will have more sensors of a social or personal nature which are more likely to trigger, leading to more alarm call handling. This will increase pressure on call handlers, but especially at night or during the weekends when previously there was little activity. Attention will need to be given to training and staffing details.

4.3 Lifestyle Monitoring

4.3.1 Introduction

The principles of monitoring domestic activities via technology in order to determine an individual's changing abilities to cope independently in their own home have been known for about 20 years. They involve the use of relatively simple, low-cost sensors and need little communication bandwidth. However, lifestyle monitoring (LM) has not evolved as quickly as might have been possible given the rapid growth in the use of the internet, web-based browsing, and mobile access to such results. Perhaps the most significant factors in slowing down the acceptance of such technologies are:

- A need to have an appropriate telecare alarm service in place as a permanent measure alongside, or to replace, a lifestyle monitoring system following a period of monitoring; current LM tools, such as Just Checking, do not integrate with other functions performed at the centre, and employ a completely different set of sensors which may not be familiar to staff at the centre
- A lack of awareness and training in the use of these technologies by professional staff who might be the main users;
- Data ownership issues; and
- Ethical problems associated with deriving intimate knowledge on personal aspects of people's lives, and sharing it with different groups.

As telecare services have matured, many of these factors have been addressed. It is therefore likely that new and improved forms of lifestyle monitoring will emerge which will be compatible with existing technologies and which will therefore be coordinated through existing alarm monitoring centres, and be acceptable to users/carers. The impact of the technology on individual alarm call handling facilities and staff may not immediately be evident but the situation is likely to change quickly as new practices are adopted and as alarm handling centres become the hub of broader well-being initiatives involving health, housing and social work.

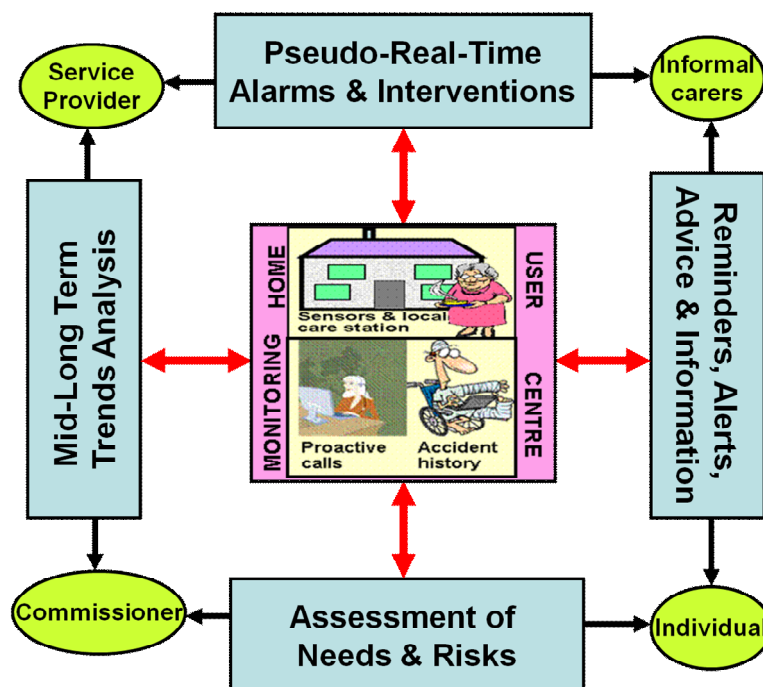

Figure 8. Applications of Lifestyle Monitoring Technologies & Services.

Four major applications for lifestyle monitoring are emerging as shown in Figure 24. They are:

- Assessment of needs and risks

- Mid or long-term trends analysis
- Pseudo-Real Time Alarm and Interventions, and
- Reminders, Alerts, Advice and Information.

These are described in detail in *Appendix 8.3.8*.

4.3.2 Overall Growth Potential

One driver for greater use of LM will be the development of new methods of recording the relevant data in unobtrusive but low-cost ways. Some of these will involve intelligent footwear, items of clothing or jewellery as shown in Figure 9.



Figure 9. Intelligent Footwear and Smart Clothing Examples.

Similarly, a range of sensors including those looking at environmental parameters such as temperature, humidity, light levels, sound levels, air quality etc will be embedded into items of furniture, or into specialist items of assistive technology such as stair-lifts, bath hoists and environmental control systems. Multi-functional digital personal assistants are already available in Japan. They are capable of operating in different modes according to the time of day or the needs of the individual. Currently, applications of the Banryu dragon (see Figure 10), for example, involve reminding the user to take medication during the day, but becoming a watch-dog at night detecting fires, floods or intruders. Relatively small changes would be needed to convert such robots into Lifestyle Monitoring data collection instruments with the advantage of being able to accompany the user wherever they go.



Figure 10. The Multi-functional Banryu Dragon Monitoring Device.

A second driver for increased use of LM will be the emergence of validated models that combine LM data with alarms history, single shared assessment data, medical history (including current vital signs information) and self-assessment information on a continuous basis. If the use of well-being indices are shown to be capable of providing early warnings of exacerbations, which may help with health promotion and with the prevention agenda, then LM will become an important element in the tool-kit of medical and social work professionals and may become an input to the single patient record. More slowly changing indices may also be useful in maintaining or improving the Quality of Life of service users through appropriate interventions, and in quality assuring pharmaceutical treatments of long term conditions and chronic diseases. The prevalence of such conditions is likely to soar over the next 20 years (see *Section 4.4.3*) largely because of lifestyle effects (mainly poor diet and lack of exercise); medication remains the primary method of management but increasingly GPs are able prescribe swimming sessions and other forms of sport as the significance of exercise becomes apparent.

4.3.3 Summary

Lifestyle Monitoring technologies are maturing quickly with applications in assessment, long term decline, intermediate care and long term condition management. Although many of the systems that are currently popular are operated independently of the monitoring hub, more sophisticated systems are appearing that utilise call handling staff to identify trends and to pass on alerts to response teams. Staff will need to develop skills to deal with various data display formats so improved and extended training will be required. It is possible that a significant number of service users will be monitored in this way for a few weeks before a package of telecare is prescribed for long term use.

4.4 Telehealth

4.4.1 Introduction

Telecare can also be associated with the monitoring of health or well-being status over a long period of time, I.e. vital signs monitoring. It extends the reactive alarm principles of first generation telecare (which focus on emergency detection) to a more responsive mode in which slower and more subtle changes are detected, often in people with chronic diseases. These data may be used to reassure an expert patient that a condition is under control as well as to demonstrate to health professionals that compliance with a treatment regime is good. This is also known as a telehealth application.

Vital signs monitoring can be effective for managing people with chronic diseases such as congestive heart failure (CHF), chronic obstructive pulmonary disease (COPD), hypertension and diabetes. It can lead to better clinical endpoints (e.g. morbidity, mortality and functional status), cost avoidance (e.g. a reduction in re-admissions to hospital due to acute conditions, travel) and improved end-user satisfaction.

4.4.2 Telehealth Equipment & Systems

The telehealth equipment in the home consists of a home telehealth monitoring unit and a range of sensors which usually plug into it are tailored to the needs of the individual to be monitored but typically consist of devices to measure one or more of the following:

- Heart Rate/ECG
- Blood pressure
- Oxygen saturation (SpO₂)
- Body weight
- Peak flow/FEV₁/spirometer
- Blood glucose
- PT/INR (anticoagulation monitoring)
- Body temperature

In current systems, vital sign measurements are recorded typically once, or sometimes twice, per day (dependent on diagnosis) to enable trends and out of limit parameters to be detected. The home telehealth monitoring unit is responsible for processing the signals and providing a telecommunications link so that data may be uploaded to a remote data server for processing. Some units also possess a user-interface (e.g. a screen/keypad and sometimes voice-based prompts) in order to:

- Provide reminders of the need to take measurements;
- Guide the user through the measurement process;
- Ask simple questions relating to well-being which can usually be answered using one or two buttons. This 'health survey' can be tailored to the circumstances of the individual being monitored

- Provide video link to user to enable 'virtual visit' to occur
- The process used in typical applications is described more fully in Appendix 8.3.9.

4.4.3 The Potential for Growth

There are a number of drivers for a growth in telehealth services, primarily the increasing incidence of chronic disease (which is increasing at all ages but more so for the increasing 75+ population) and which is likely to continue to rise due to a number of reasons, including the ageing population, sedentary lifestyles, smoking, obesity and improved survival rates of previously fatal conditions. Chronic disease is a big problem across the UK - in Scotland, it is estimated that around a million people have at least one long-term condition and that nearly a third of households contain at least one person with a long-term condition, in Scotland ^[13,14,15]:

- Almost 200,000 people have been diagnosed with diabetes in Scotland with potentially many tens of thousands undiagnosed.
- There are over 99,000 people with COPD in Scotland. The rate of Chronic Obstructive Pulmonary Disease (COPD) is higher in Scotland than the rest of the UK with 18 cases per 1000 population^{vii} (compared with 13.5 in England (QoF data 2006))
- The prevalence of hypertension is approximately 12% of the population but it is thought that only about half of those with hypertension are known to the health service; of these, only about half receive any treatment; not all will have their hypertension adequately controlled

It is well known that poor chronic disease management leads to wasteful use of high intensity resources such as hospital beds (half of bed day use is accounted for by only 2.7% of all medical conditions, most of which are chronic diseases ^[16]). There are therefore a number of initiatives underway to try and better manage this problem, including self-care and expert patient programmes and the adoption of technologies such as telehealth. Evidence is beginning to appear to show that telehealth can help to reduce incidences of hospitalisation (or re-hospitalisation) and significantly reduce the number of bed-days^[17]. To put this into context, the Scottish average is 1.33 bed-days per COPD patient per annum with an overall cost of over £40 million^[18].

^{vii} Source: Practice Team Information (PTI), ISD Scotland, as at 25th March 2008.

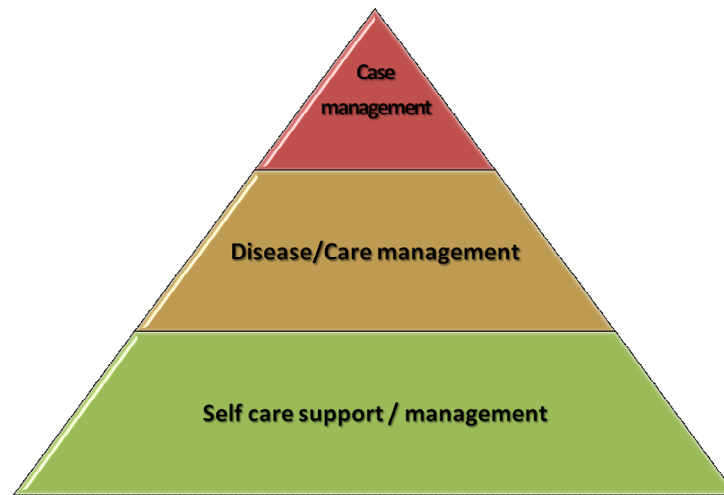

Figure 11. Chronic disease model.

Figure 11 shows the chronic disease model based on the Kaiser Permanente pyramid. The bottom level represents between 70-80% of a chronic disease population who are felt to be able to self-manage their condition. Traditional telehealth services have been aimed at the top of the long-term conditions pyramid i.e. for individuals with multiple complex conditions who require case management. There may be a roll for telecare monitoring centres to support care management through the recording of individual parameters on a regular basis- and this is discussed in further detail in 4.4.4. This includes people with Type 2 diabetes, obesity or hypertension who only need to measure one parameter ever other day or once a week. This self-care or expert patient approach has resulted in a number of telehealth 'lite' monitoring units which offer a lower cost easy to use approach to remote medical monitoring using personal health monitoring devices. Other techniques involve incorporating such measurements into a proactive care service or systems that allow a user to manually enter data using the keypad on their telephone. Recent reports have indicated that some people with low-level needs may not benefit from self-monitoring regimes ^[19,20].

4.4.4 Impact on Monitoring Centre

A telehealth monitoring service may currently be operated completely independently of a telecare monitoring centre as the monitoring platform upon which it operates is completely separate from that of the alarm-based telecare infrastructure and it is not an alarm-based service where a real-time response is required. Furthermore, the end-user of the data is usually a nurse or clinician of some form – a role not usually associated with telecare monitoring centres. However, there are a number of factors which make operating a telehealth service from a telecare monitoring centre a logical proposition:

- There is a need to have a certain amount of IT and telecommunications infrastructure in place to ensure that the telehealth data can be hosted reliably and securely and that the data can be accessed remotely by all stakeholders who require access on a 24/7 basis. This involves system backup and continuity issues

as well as data protection.

- A significant proportion of alerts that are generated from telehealth equipment are not 'red' – often alerts are due to missed or incomplete readings (e.g. if a client didn't feel well or there was an error in taking a measurement). These alerts need to be followed up by phoning the client to investigate and advise, which takes time and is perhaps not a role that uses the time of clinical staff effectively. Therefore, with telehealth monitoring there is a need for **non-clinical triage**, a role which the telecare monitoring centre is well-placed to perform as the approach may be similar to existing telecare protocols, and represents a more cost-effective use of skilled staff time.
- Even when 'red' alerts are generated (due to monitored data being out of range or based on answers provided to the health survey), response protocols normally request that a re-test is made (for monitored data) prior to requesting additional information. Only then is a decision made on what the most appropriate action to take is (e.g. referral to GP/A&E/Case or Care Manager). This initial task is again suitable for a non-clinical role.
- The introduction of medically-related telecare alarms (such as blocked catheter alarm) and the availability of body-worn monitors will enable real-time medical **alarms** to be generated, which will need to be handled by suitably trained call-handlers.
- The eventual convergence of telecare and telehealth platforms within the home and protocols and standards throughout the system will mean that alarm-management will become possible using an integrated platform.
- Patients who suffer from chronic diseases often experience a number of social care problems for which telecare solutions may be appropriate. By combining the health and social telecare agendas, continuity of care may be improved.
- Current telehealth equipment does not give alarms, so patients who need help are likely to continue to use traditional A&E and primary care services unless they are provided with a single point of contact. Call handling services that may simply be required to provide advice and reassurance are available at night and during the weekends to ensure that potential emergency situations are dealt with effectively and efficiently.

In terms of staffing requirements, the role of non-clinical triage is clearly different from normal call-handling as it is a task that might typically be performed at a set period of the day (perhaps each morning) and involves responding to alerts by phoning up the client and then providing assistance/guidance as required and then following an agreed response protocol depending on circumstances.

Data from a telehealth trial undertaken by the Western Cheshire primary care trust using a monitoring centre run by 'Chester Care' showed that for 10 patients monitored over 144 days there were 682 readings taken of which 267 resulted in some form of red alert (39%)^[21]. The processing of alerts took 216 hours, which corresponds to an average of 1.5 hours a day to process data from 10 users or an average of ~ 9 minutes per user per day. 'Chester Care' reported an increase in referral rates for telecare due to the telehealth project, probably due to an increased awareness amongst healthcare staff. Indeed, there is an argument that suggests that it is good practice to provide a basic telecare package with telehealth in any case as it can provide an easy means of obtaining support for users.

The alternative is to employ a nurse to undertake the triage of telehealth data. They might be needed only at the time when the data come in (perhaps for a couple of hours in the morning and a couple of hours in the evening) in order to respond quickly to red alerts. However nursing staff may only be available during weekdays leaving no cover for weekends. Such an approach would provide more expertise but would cost more and might not be an effective use of the nurse's time/skills. Some trialling of this approach is going on at the moment.

Some of the practical steps in establishing a telehealth service include:

- Agreeing partnerships and service level agreements with health boards, trusts and related stakeholders;
- Ensuring that there is adequate IT infrastructure in place (telecommunications links, data server, software & networking) to provide a reliable and secure service and which enables remote access to data for clinicians;
- Ensuring that there is adequate IT support available to perform day-to-day maintenance of the system in relation to performing data backups, ensuring firewalls and anti-virus software is up to date, etc.
- Developing alert response protocols;
- Training:
 - General awareness training (including service users & their family carers);
 - Operating telehealth software;
 - Non-clinical triage response protocols & actions;
 - Troubleshooting common equipment problems and follow written troubleshooting guidelines;
 - Establishing procedures for emergency back-up/replacement of equipment, maintenance and service-continuity; and
 - IT support (if necessary).

In the future, and when broadband communications are available to the homes of all people, video consultations may become popular. Monitoring centres may become involved in ensuring that the communications links, the sound quality, the camera positions and issues of picture brightness and colour balance are addressed before a connection is made to the healthcare professional. This is discussed further in *Section 4.10*.

4.4.5 Summary

The development of a telehealth service could be a natural “next step” for telecare service providers. There are significant economic factors that will provide the drive for new services to deal with patients who have chronic diseases, while the technologies based on web-2 have matured quickly. Alarm handling centres may play a big part in the roll-out of telehealth services providing that they invest in additional training and have the appropriate skills to understand the applications.

4.5 Proactive Calling

4.5.1 Introduction

Social and community alarm services often telephone service users on their birthdays to offer them good wishes. It is sometimes the only call that they receive on this day and is clearly valued by the recipients. This is the simplest (and least frequent) example of pro-active calling. A more likely application is a weekend check call for someone who benefits from a mobile warden service during the week but has nobody to ensure that all is well on Saturday and Sundays. This could be viewed as a preventive and responsive service rather than a reactive one. As such, it may be regarded as significantly different to an alarm service, though most providers use the same team of call handlers.

More recently, proactive calling has been extended in many areas in England including many London Boroughs to support people recently discharged from hospital, and as an obvious method of trying to ensure that they are rehabilitated successfully into the community. Evidence from Birmingham suggests that such services may significantly reduce the rate of readmission to hospital within 90 days of an original discharge by 48% ^[22]. Elsewhere, social work departments are seeking reassurance check calls to other groups of vulnerable people who don't necessarily need a social alarm but who are nonetheless prone to rapid decline. These groups of people might include those with a history of depression, isolation and social exclusion.

Computer Assisted Interview techniques have also been proposed which use a range of appropriate questions together with a scoring system which allows sudden changes to be automatically flagged. They are being piloted in some counties in Wales as a low-cost method of extending the base of telecare users without involving capital expenditure. In principle, they only need a telephone, though the service is most easily provided to those who already have

an introductory level of telecare (i.e. a care phone) Services involve twice or three times a week calls to people at risk of social exclusion and are designed such that different questions are asked on each occasion during the week to ensure that the service user doesn't become bored by having to answer the same questions each time. This approach is based on the successful OwnHealth project involving Birmingham East and North PCT, NHS Direct and Pfizer Health Solutions, details of which are provided in *Appendix 8.3.3*.

In order to achieve savings in the order of £400 per participant per in Birmingham without the scale of investment provided by NHS Direct and Pfizer health, it may be appropriate to try to maximise the impact on a whole raft of other services provided by the local authority. This might involve ensuring that the right people are offered the service, and ensuring that the service provision is efficient in terms of support scripts. As there are currently no validated scripts then there can be no validated training courses, though these are likely to quickly follow the introduction of the Welsh services.

4.5.2 Impact Summary

A properly trained call handler will be able to utilise the script effectively and will be able to reduce conversations to 10 minutes through bringing them to a close in an appropriate manner. Nevertheless, there may be significant costs associated with the telephone service, and also with creating the capacity to deal with potentially dozens of calls per day. On an eight hour shift, the maximum number of service users receiving a call will be 48. However, as service users may choose to book their calls during specific windows during the day, the maximum number of available slots is likely to be halved with some calls having to be deferred.

It follows that some members of staff will need to perform these routine duties from the comfort of their own homes. This will require the extension of existing telecoms provision to the home of staff members so that they can put in their hours remotely. This may involve the use of Voice over IP (VoIP) in order to minimise telecoms costs. It will, however, involve attention to issues of health and safety and of data security in the homes of call-handlers who are involved in such tasks.

4.6 Domiciliary Care Monitoring

4.6.1 Introduction

Community services to support independent living outside of care homes will increasingly become complex packages consisting of different care elements likely to include domiciliary care, meals services, day care, aids and adaptations, housing support and telecare services. Any failing of these services may be reported as an emergency through the social alarm system, but might also be detected automatically using telecare. Such processes may become an integrated part of care delivery if domiciliary care is scheduled and monitored by the call

handling centre, especially if dedicated software is operated on the monitoring centre platform. This needs a higher level of integration to take place involving care planning/IT system, technology etc.

There can be little doubt that homecare services are, and will continue to be, the most significant element of the support and care package for many years. It follows that telecare services are likely to adapt so that they can incorporate as much functionality as possible that may be relevant to the homecare sector. This would, in its simplest form, include a means of identifying the relevant domiciliary carer if an alert is received which complains about a carer/health worker being late. This would enable the alarm centre to telephone to find out the problem so that the service user can be advised of the likely time of arrival. Then, if the delay is significant, an alternative home carer/health worker may be summoned.

In the same way, if a telecare alert has been signalled because a particular service user has perhaps suffered a fall in their home, then a member of the homecare team may be the most appropriate responder and may be summoned, especially if their location is already known to the centre. If the service user is subsequently admitted into hospital, then the centre may also be able to advise the home carer or the agency so that they don't provide wasted visits until the service user returns home.

4.6.2 Extending the Application

As an increasing percentage of homecare services are outsourced to external domiciliary care agencies, the role of the social work department may become one of monitoring the delivery of care and ensuring that the quality of care provided is up to the required standard. In particular, this means checking that the required volume of care is consistent with the time allocated in the care plan. This involves recording the time of arrival and the time of departure of the carer. There are a number of different methods of logging this information, many of them dependent on the use of bar-codes, mobile phones and electronic tags. The simplest techniques employ the telephone in order to register identity, arrival and departure. Early systems actually dialled out with this information while modern telecare receivers perform this task automatically, enabling software at the monitoring centre to generate invoices according to the actual period of care provided.

A second, and more complex, requirement may be in ensuring that the tasks performed by the homecare personnel are consistent with the care plan. A spot check might be performed automatically (using Lifestyle Monitoring data for example) to ensure that a contractor is delivering the service that he or she has been paid to provide.

4.6.3 Impact on Call Handlers

Spot checks require some level of human intervention, so it follows that call handlers may be in the best position to perform them. Training would be required to ensure that appropriate

procedures were employed, especially when the data suggest that the home carers are not performing the required tasks. Flexible care delivery is generally encouraged so the call handlers will need clear protocols to follow when dealing with this type of incident.

4.7 Access Management

4.7.1 Background

Good training and alarm handling protocols mean that the majority of alarm calls from social alarm or telecare systems can be dealt with by informal carers without the need for a physical response. However, there will inevitably be times when the emergency services or an out-of-hours doctor will be required to deal with an accident, illness or an acute condition which requires hospital treatment. Similarly, in the event of a fire or a gas leak, there will be a need for immediate access to a property in order to minimise the potential damage caused. Increasingly, mobile teleresponders may need access too in order to deal with social or medical problems when the service user is unable to open the door due perhaps to a non-injurious fall which has left them on the ground but incapable of getting up on their own. There are three main solutions to this problem:

- **Rely on a family member, neighbour or friend as a key-holder** - this approach works well provided that they can guarantee to be available at all times and to provide access within, say, 20 to 30 minutes depending on geography and traffic levels. To provide confidence, a number of key-holders may be needed, whose contact details and schedules are held by the alarm handling centre. As families spread out geographically, it is becoming increasingly difficult to recruit suitable key-holders and to audit and maintain the list. There are particular issues in a rural context where distances between neighbours can be considerable and road links poor.
- **Key-holding service** - a key to every property receiving an alarm service is held in a central repository (or in several satellite or mobile locations including secure vans). This approach overcomes the problem of unreliable or unavailable key-holder but places great demands on the response service who may need to be in two places at the same time. When keys are carried in vans, it is essential to label the keys with codes rather than with names and addresses in case the van is stolen. In this case, management of the codes is vital to ensure that the correct key is selected to fit the service user's lock.
- **Key-safes and electronic access** - a key to open the front door (and any door-chains too) are kept securely in a miniature receptacle securely bolted to the wall of the property. Access to the key safe is achieved using a digital combination. In the same way, there are digital door locks that can provide access to anyone who knows the combination. Examples of these technologies and their relative

advantages and disadvantages are discussed in *Appendix 8.3.4*.

4.7.2 Role of Monitoring Centre

In each case, the role of the alarm monitoring centre is absolutely pivotal in managing access either through the safe and robust management of access codes or of the information needed to identify a genuine visitor or emergency responder. Although video access is only being tried initially in schemes, the cost of the communications hardware is falling so quickly that individual domestic situations will utilise this form of management very soon. It requires the monitoring centre to have systems that are compatible with IP-based networks (over ADSL) and video telephony.

4.8 Location Based Systems

4.8.1 Background

Asset management originally involved the placement of a transponder inside a motor vehicle or an element of heavy machinery or plant (such as a JCB) so that they could be located in the event of theft, or if needed in a hurry. It is now used extensively by service organisations who need to know where their technical or support personnel are at any time, so that they can direct the most appropriate team to an incident as efficiently as possible. In each case, the transponder system can be hidden away inside an engine compartment, and can draw power from the vehicle battery. Size is not generally a problem in these applications, neither is appearance as the device should not be visible.

However, when an individual needs to be tracked, the practical problems are much more evident though, perhaps, secondary to the ethical dilemmas facing organisations that are attempting to tag someone. Generally speaking, and neglecting the possibility of tracking prisoners released early on licence or similar individuals such as youth offenders, the two biggest application groups are elderly people who are suffering from a cognitive impairment (or dementia) and people who have a learning disability.

The former are a challenge because up to 40% of people with Alzheimer's Disease, for example, are known to leave their property at some stage, usually at inappropriate times such as the night ^[23]. Their motivations vary, but they often report needing to visit someone or some place that is important to them. This desire may be triggered by very old memories, so they often fail to find what they are looking for and become lost. They may be found wandering some distance from their homes. As they are likely to lack insight, they may be particularly at risk of being involved in a road traffic accident. In the same way, they may not be dressed appropriately at night and may end up suffering from exposure. The latter may simply become lost and, because of communication deficits, may be unable to articulate their problems to others; they are also liable to abuse when they are lost and frightened.

Most people with a dementia or with a learning disability will live in dispersed properties in the community where they can continue to live as independently as possible. This means that external doors will not be locked, so there will be a risk of the person exiting the property, and a risk that they may not return within a reasonable period of time. Such arrangements are usually entered into with the knowledge and support of the individual and his or her family where appropriate. It does lead to new risks, but these may be moderated and made acceptable by having the means of locating a person at any time using tracking technologies

4.8.2 Tracking and Location Technologies

Tracking involves the use of either triangularisation using GSM technology (which has a resolution of a few kilometres in areas where mobile phone cells are low in density such as in rural areas) or GPS satellite technology. Both can be provided using mobile phones and this type of service has been offered by some London Boroughs for a number of years following the original work in West London by Dr Frank Miskelly at the Hammersmith Hospital. Tracking of mobile phones is usually performed by a third party organisation associated with the mobile telephone network. However, the telecare alarm handling centre can appear in the loop as an interface, especially when the telecare alarm has already indicated that the person has left their place of safety.

Devices based on GPS technology, but not based on a convention mobile phone (at least not in appearance) are now emerging. They are described in some detail in *Appendix 8.3.5*. Most have a conventional GPRS link to allow conversations to take place or for activation in the event of an emergency. This also allows for location by triangularisation when the GPS satellite isn't visible as is generally the case indoors. GPRS technology works in most buildings and also under arches and in multi-storey car-parks. However, whilst GPS gives a location accuracy of better than 50 metres (which can be improved to 5 metres in systems employing Differential GPS), the accuracy of GPRS location depends on the density of phone masts. This means that accuracy may be 200 metres in cities but 2km in the country-side. It should be noted that there are areas of Scotland where there is no GPRS coverage – but similar restrictions do not apply to GPS.

4.8.3 Locating People Inside Properties

As mentioned above, GPS only works where there is a line of sight to the satellites. Despite its good resolution, it may not be useful in providing location information inside properties. As the number of people supported in the community increases, then there will be times when many people who are at risk of different accidents are located in fairly close proximity, often within an Extra Care housing scheme or in a EMH facility. Some people will be perfectly safe left alone to come and go as they please, whilst others may be unsafe close to water, in a kitchen or at the top of the stairs. In such cases, there is a need for a different type of location system – one which provides alerts as people move around inside rather than outside a property.

In the same way, Lifestyle Monitoring systems will need to differentiate between clients and their carers. Security systems will need added flexibility to alarm some rooms and doors for some personnel but not for others. Mesh networks are evolving which utilise wi-fi or similar wireless communications on a room-based arrangement enabling computer systems to be programmed to match the needs of properties with multiple occupancy. *Appendix 8.3.6* describes the Amego system designed for care homes while the AlertMe system allows an existing wi-fi network to be extended to include a range of sensors for security purposes.

4.8.4 Impact on Alarm Handling Centres

Although individual families may choose to invest in these technologies themselves, it is likely that the most popular arrangement will be for tracking aids to be provided as part of the telecare provision, and especially where a property exit monitor is used initially to provide an alert. In this case, the alarm monitoring centre is ideally placed to initiate a location request and, if the protocol demands, to inform a mobile response team. Thus, the alarm handling centre becomes the coordination centre. They will be able to contact the emergency services or the telecare staff according to the situation and the location of staff. Events may be few, but when they occur, they will be intense.

4.9 Existing/Emerging Applications of Telecare

While social alarms (or Personal Emergency Response Systems) are generally known as medical alarms in the USA, they are known as “teleassistance” in Europe where the focus has been on providing vulnerable people with a secure means of raising an alarm in the event of a security incident. This application has been secondary in the UK but, as the technology has improved and incidents of false alarm decrease, the opportunity of relieving anxieties of people regarding incidents of security is evident. The success of the “bogus caller” solution clearly demonstrates the significance of this application. It follows that where security-based telecare systems are provided, the alarm handling centre will need to work more closely with the police and with crime prevention officers in ensuring that adequate protocols are in place for dealing with reported incidents.

Five additional telecare applications are worthy of further consideration because of the changes in working practices that may be required and these are discussed below.

4.9.1 Supported housing

The number of people with physical or learning disabilities who live in hospital accommodation continues to drop in line with government policy. The community model involves building new properties (or adapting existing ones) to eliminate problems due to steps and other access issues, bathing and other environmental concerns. However, the vulnerable people who live in such homes are prone to abuse by anti-social elements who may attempt to enter the property inappropriately. Although there may be support staff in the home, this may be limited to one

person who may be unable to deal with incidents as they arise. Remote monitoring may therefore be appropriate, and may involve responding to alarm calls from intruder detection devices and systems, or the use of video cameras to search for potential offenders close to the property.

This application is similar to the use of CCTV in town centres, except that the telecare-based systems may be activated only in the event of a trigger from a sensor. The same technology may be used inside a property when no staff member is on duty, or when the only member of staff is sleeping. It may be used to confirm or authenticate a problem initially detected by telecare sensors including, for example, a fire or movement in a potentially dangerous location (such as the kitchen) during the night. The alarm handling centre may be required to provide feedback through a speech channel which may become a challenge to an intruder or a prompt for a tenant. Such applications may not be limited to supported housing but may be extended to hostels for battered wives, temporary accommodation for people suffering from drug or alcohol abuse, asylum seekers or people with mental health problems. They may employ lifestyle monitoring systems also when a record of activity is needed.

4.9.2 School and Public Building Security

School premises are one of the most likely types of property to become the target for vandals and arsonists. It is often ex-pupils who have a grudge against the establishment or against particular members of staff who are responsible for millions of pounds worth of damage every year ^[24]. A high percentage of arson attacks occur at night, during the weekends, or during school holidays. This is because both the staff and the students are away from the school and because pupils have time on their hands. The result is that the damage is often far more serious, and causes considerable disruption to teaching as well as the cost of performing repairs. Telecare systems can provide an electronic safety blanket around schools through the widespread use of sensors to detect movement at inappropriate times and signs of environmental problems at all times. They can raise alerts at different levels enabling the call handling staff to deal with the problem in a variety of different ways according to the time and available resources. In the event of a fire, monitoring centre staff can confirm the type of incident, summon the fire and rescue services, and operate water mist or sprinkler systems as required. Voice messages might also be employed to advise staff and pupils what they should do. In the event of floods (which often occur in external toilet blocks as a result of freezing conditions on winter nights), water supplies may be switched off remotely to minimise damage.

Other opportunities for telecare support in schools includes the use of electronic thermometers to indicate the failure of heating systems to operate correctly in winter, or the use of humidity gauges to detect dangerous conditions during the summer months. Some staff members might also be issued with triggers if they are vulnerable to attack at any time. In each case, the

response protocols are markedly different to those for dealing with vulnerable older people, so a different type of alert classification may be needed. In particular, during the night or school holidays, protocols may need to be changed to account for the availability (or otherwise) of caretakers, head-teachers or other relevant personnel. Alarm handling centre may need to be proactive in finding out in advance the travel plans of contacts rather than wait to be informed.

4.9.3 Criminal Justice System

The prisons are full; new ways of controlling criminals are being sought which don't involve custodial sentences. Electronic tagging has been introduced, but compliance has been variable. In particular, these systems are not successful in preventing tagged individuals from spending periods of time outside and on the street rather than inside, due to the range of the tagging equipment. Telecare enables the context of tagging to be improved with alerts being generated, for example, if the exit door is left open during curfew hours, or a lack of movement is observed when the offender is supposed to be indoors. New monitoring applications will emerge by combining tracking and sensor technologies. This may involve alarm handling centres having to ring the offenders when the systems detect a problem.

While the systems can be employed in individual properties, applications may be extended to bail hostels, police custody cells and to various forms of remand institution.

4.9.4 Fire Protection

As the advantages of linking smoke detectors to a telecare system that enables alarms to be linked into a 24-hour monitoring centre are increasingly recognised, there will inevitably be a surge in the number of false alarms. These are calls generated when a kitchen accident occurs or when someone smokes a pipe or cigarette too close to a detector. They are not serious incidents, nor do they justify the immediate presence of the emergency services. Yet, existing response protocols employed in many areas demand that a smoke detector or high temperature alarm activation should lead to an immediate 999 call and a request for an emergency appliance and crew.

An audit of emergency call out in the Tyne and Wear area has shown that 52% of all false alarms from smoke detectors occur in domestic properties. In such cases, little or no action is required from the fire fighters in 99% of call outs ^[25]. Hence, resources are stretched and appliances are unavailable when a genuine emergency occurs. The approach adopted to reduce the effects of inappropriate calls outs includes:

- Reducing the number of fire signals;
- Reducing the number of false alarm apparatus calls;
- Reduce the number of fire damage reports;
- Providing Fire Risk Assessment Training & Installation advice for telecare service

providers;

- Introducing “Call challenge” training for telecare centre call handling staff;
- Providing support plans to include Home Fire Risk Assessment;
- Reducing fire risks allowing residents to remain independent within their own homes.

The need for improved partnerships will increase the work load on call handlers but may quickly benefit the community through improved response times.

4.9.5 Lone Worker Protection

Lone workers are those people who work by themselves without close or direct supervision. Health and safety rules dictate that an employer has a duty of care to its employees and that suitable arrangements should be put in place to minimise the risks associated with lone working. Lone-workers are found in a wide range of situations, including:

- People in fixed establishments, where:
 - only one person works on the premises e.g. in small workshops, petrol stations, kiosks and home-workers;
 - people work in separate areas from others, e.g. in factories, warehouses, leisure centres, etc.
 - people work outside normal hours, e.g. cleaners, security, maintenance or repair staff, etc.
- Mobile workers working away from their fixed base:
 - on construction sites, plant installation, maintenance and cleaning work, electrical repairs, vehicle recovery, etc;
 - service workers, e.g. rent collectors, postal staff, social workers, home helps, district nurses, speech & language therapists, pest control workers, drivers, and similar professionals visiting domestic and commercial premises.

There are a number of different types of lone worker service as described in *Appendix 8.3.7*.

Lone worker protection is well suited to a telecare monitoring centre situation and is well-established in a number of call centres across Scotland and the rest of the UK. Lone worker modules are therefore included in all major telecare monitoring centre call-handling software packages. The automated nature of the newer systems means that the impact on the monitoring centre staff is reduced to an alarm-based response only.

4.10 Video-Based Support Services

4.10.1 Background to Services

The gradual replacement of dial-up services by ADSL and other high-bandwidth broadband technologies will be an enabler for many of the applications described previously. In terms of video-based applications, most will only involve:

- bringing video data into the home for information, advice or entertainment purposes i.e. an essentially one-way application; and
- video telephony (or virtual presence) applications which can help to overcome the problem of distance, allowing service users to become involved in video conversations and interactions with family members, thus reducing the number of socially isolated people.

Neither of the above involves the alarm monitoring centre other than as a facilitator of the service. Technically, the centre becomes a modern telephone exchange, joining together two video cables rather than simply two audio cables. It follows that the process can be automated in the same way as a telephone exchange allows switching to be performed without human intervention. However, there are likely to emerge some applications which require the end-user (i.e. the telecare customer) to first engage in a video telephony interaction with a call handler at the centre. A number of examples have been proposed:

- help with telecare interface equipment such as a remote control handset – the call handler may show the service user how to change the batteries for example;
- video consultation with a health professional – a nurse in the monitoring centre will be available to view damage caused by an accident in the home, or to provide advice based on their visual characteristics;
- remote prompting and surveillance - the alarm handling centre uses a PZT (pan, zoom and tilt) camera to guide the service user to objects during a session in which they are instructed to prepare a meal or to perform an activity;
- support for taking vital signs or environmental measurements using equipment that may have been delivered to the property;
- health coaching – advice on food purchase and preparation is provided to help moves towards healthy eating; and
- exercise and rehabilitation – alarm handling operatives may provide the personal coaching that people may need to increase their activity levels in order to maintain their health status.

4.10.2 Impact on Monitoring Centre

These services generally rely on staff at the centre being up-skilled to deal with a number of new and different situations but with one-to-one connection possibilities. Staff will necessarily be visible and their appearance will become relevant. They may need to wear uniforms and centres may need to be redesigned to appear more like a television studio.

4.11 Review of Impact of Future Telecare on Call Handling Services

- **Basic Community Alarm Services (Introductory Telecare)** – numbers receiving this level of service may decline for a number of unrelated reasons. The actual rate of decline may depend on how quickly new services are introduced, but also on the charging structure proposed
- **Extended Alarm-Based Telecare** – this is likely to increase as quickly (and hopefully more quickly) than the decline in basic services. The number of people using this level of service may be limited to a percentage of those receiving other community services. The standard of call handling needed to satisfy increasingly vulnerable clients will need to improve, and will need formal training courses.
- **Lifestyle Monitoring** – applications of LM are likely to increase rapidly as the evidence grows for their value in a wide range of area. Data will be collected in call handling centres where staff may need to perform more analysis of data and perform responses based on these data. Applications will need to be supported by significantly more training.
- **Telehealth** – remote vital signs monitoring will be performed on increasing numbers of people with chronic disease. Appropriate management of their conditions will involve new relationships with staff at the alarm handling centres who will need some medical training to deal with new problems.
- **Proactive Calling** – the use of computer assisted interview techniques will allow many people to be supported at home because potential problems are being detected automatically. Call handlers will need to initiate calls proactively and to engage in conversation and interview with service users. There may be significant training needs to address.
- **Domiciliary Care Monitoring** – the budget for domiciliary care dwarfs that for telecare, so it is important to ensure that value for money is obtained. Telecare can be used to indicate the start of a session of care but also to quality assure care delivery through spot checking. Call handling staff will need to be trained in detecting anomalies and in dealing with such situations.
- **Access Management** – an increased use of key-safes will require greater emphasis on data management principles to avoid situations where they key is

removed by relatives or where inappropriate access may be provided.

- **Location Based Systems** – the maturity and miniaturisation of GPS devices will produce a surge in products capable of providing location information. The alarm handling centre will be used by most systems as the hub to coordinate the efforts of responders to find people who have become lost.
- **Existing/Emerging Applications of Telecare** – there are many other applications of telecare that are likely to shape future services according to local priorities. In each case, call handling staff will have to learn new ways of working and of responding to emergency situations.
- **Video-Based Support Services** – the call handler’s role may become more that of a television interviewer as far as video consultation technologies are concerned. Appearance and facial gestures make become as relevant as words.

5. Discussion

Section 3 revealed how changes in materials, sensors and information and communications technologies are likely to change the way in which telecare may be delivered in the future. *Section 4* then identified the current and future telecare applications and their impact on service providers. We now discuss the way in which different partnerships may address the issues of change in order to provide their populations with the most appropriate services delivered in a cost-effective manner.

5.1 Issues Concerning Service Capacity

5.1.1 Target Groups

Many of the new service applications described in *Section 4* will be relevant to relatively small groups of people. More effective targeting may help to identify those people who may best be supported with telecare services. Figure 12 shows the population of people aged 60 and over in a 6 tier pyramid of need ranging from those who are confident, fit and well, and able to self-care (and hence not requiring telecare services) at level F, through to people who need a number of different telecare services in order to deal with specific and difficult problems (level A). The diagram also shows a typical telecare package for people at each level of this pyramid based on an ascending level of need. At the base of the pyramid are those services that are available to all without assessment. They include NHS24 and general advice relating to diet, lifestyle and risk. A standalone smoke detector and carbon monoxide alarm might also be relevant. At the tip of the pyramid might be included any specialist service or technology as described in the previous sections. There is no obvious limitation; level A could include people who experience substance or alcohol abuse for which lifestyle changes could be encouraged using some of the approaches described previously.

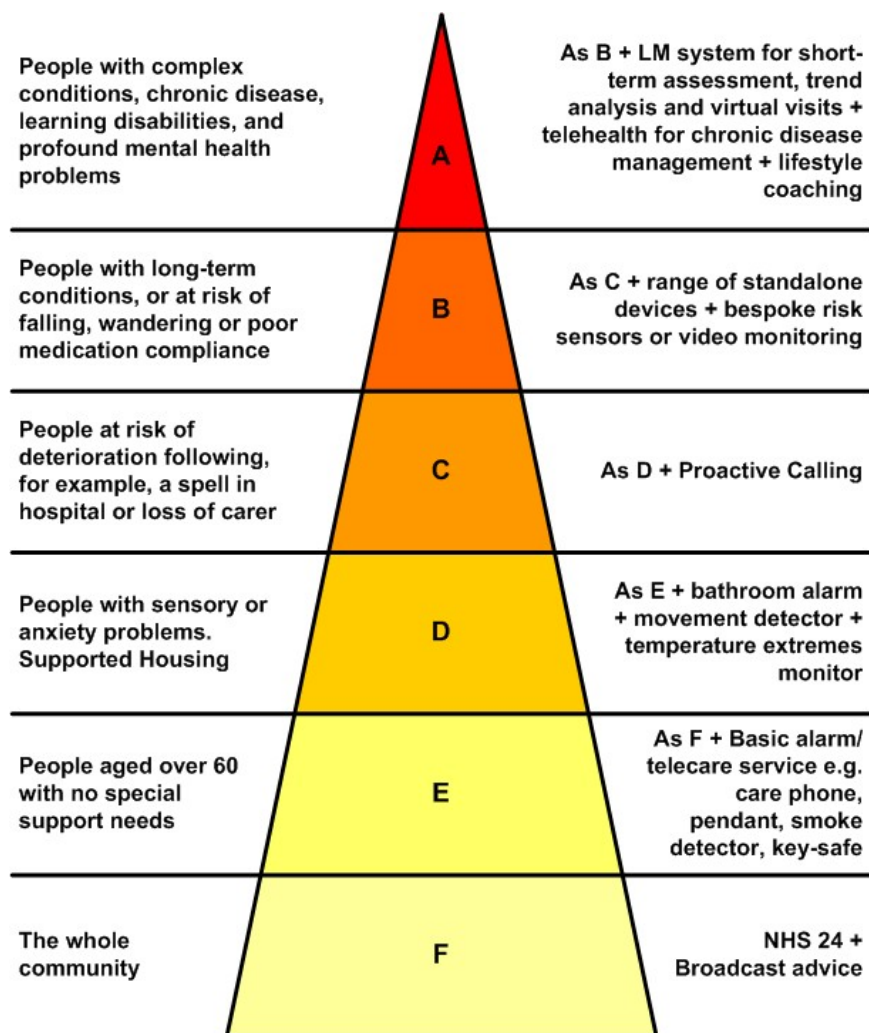

Figure 12. The Telecare Pyramid Matching Services with Needs.

The challenge is to determine how many people are likely to require and receive services at each level over the next few years. This demand will be important in assessing the required level of investment, resources (including staff) and the operational costs to service these new applications.

5.1.2 Levels of Intervention

Table 3 assigns each telecare application to one of the levels identified in Figure 12, and also described the major types of intervention required. It may be noted that some applications may be assigned to more than one level as different partnerships may choose to offer some services across levels.

Table 3. Assignment of Telecare Applications to Different Needs Levels.

Telecare Application	Type of Interventions	Level of Application
Basic social/community alarms	Emergency response + battery management	E
Alarm telecare	Emergency response + battery management	D
Lifestyle Monitoring	Exception reporting + advice/prompting	A
Telehealth	Non clinical triage + In-bound requests	A
Proactive Calling	Regular out-going calls + Exception reporting	C, D
Domiciliary care monitoring	Exception monitoring + reassurance calls	C, D
Access management	Emergency response + administration burden	D, E
Location based systems	Emergency response + Information request	B
Existing/Emerging Applications of Telecare Schools Security	Emergency response + remote controls	C
Lone worker monitoring	Emergency response + information request	C
Smoke detector management	Emergency response + administration burden	D, E
Video-based services	Prompting & support + Information request	A, B

It may be apparent that the rate of development and uptake of these application areas will vary significantly across different partnerships. However, the drivers to extend this range will be the same across Scotland as discussed in *Section 2*. Based on a number of assumptions ranging from demographic trends through to the changing costs of technology, Table 4 describes how many people may receive services in each band over the next 5 and 10 years respectively. These data are, of course, only predictions and might therefore be shown to be optimistic if investment doesn't appear to establish them at the appropriate levels. On the other hand, it is also possible that there will be a surge of interest in telecare services from private individuals who will see the significance of telecare as an enabler of choice, and will therefore buy into services according to their own perceived needs and risks. It may be worth remembering that private social alarms systems have been operated by charities such as Age Concern (Aid-Call)/Hanover Careline for a number of years, and have attracted tens of thousands of customers. It is unclear what percentage of these live in Scotland nor whether they chose not to use a local service because of concerns over quality or whether the

marketing of UK-wide services was superior to that of local providers, access criteria. It may, however, be evident that telecare services need local delivery even if call handling is provided at a distance – so the need for local partnerships to improve the promotion of their services is apparent.

Table 4. Predictions for Current and Future Telecare/health User Numbers

Group	Current Numbers	2013	Assumptions	2018	Assumptions
A	100	2000	<i>Rapid growth</i>	5000	<i>Better targeting</i>
B	1000	4000	<i>Good business case for telecare</i>	10000	<i>Improved evidence of success in this area</i>
C	2000	5000	<i>Reasonable growth</i>	12000	<i>Increasing demand for independence</i>
D	5000	10000	<i>Limited investment by</i>	20000	<i>Growth in new facilities</i>
E	183,000	200,000	<i>Effect of grant Local investment</i>	250,000	<i>Improved equipment Lower prices</i>
F	1,100,000	1,250,000	<i>Demographic factors</i>	1,500,000	<i>Demographic factors</i>

Table 4 is a prediction for the growth in the number of social alarm/telecare users in Scotland over the next 10 years. It is based on a number of assumptions made by the authors (which are listed); these are used to determine that the total number of service users may increase to over 220,000 by 2013 and to nearly 300,000 by 2018. During the same period the proportion with basic equipment is predicted to have fallen from over 90% down to little over 80% as more sophisticated equipment is used to deliver more advanced applications. In order to estimate the impact of such changes on the call handling centres, we need to consider the level of activity associated with each of the applications.

5.1.3 Impact of Interventions on Resources

Firstly, we need to distinguish between those tasks that are performed only at the alarm handling centres from those that could be performed there but which aren't necessarily part of these responsibilities. For example, the cleaning, recycling and storage of equipment may be routinely performed by call-handling staff as part of their duties when they are not answering calls. However, these functions might also be externalised or performed by equipment loan store staff. We need also to consider the different staffing models employed across Scotland.

Some centres use specialist call handlers, installers and responders; other use generic workers who can perform any or all of these tasks. This provides flexibility but at the price of increased training needs for staff.

Table 6. Intervention Times for Each Telecare Service (author estimates).

Telecare Application	Average Number of Incidents per user per annum	Average time per incident	Annual Incident Time per user
Basic social/community alarms	2	15 mins	30 mins
Alarm telecare	3	20 mins	60 mins
Lifestyle Monitoring	5	30 mins	150 mins
Telehealth	20	15 mins	300 mins
Proactive Calling	100	10 mins	1000 mins
Domiciliary care monitoring	2	15 mins	30 mins
Access management	2	15 mins	30 mins
Existing/Emerging Applications of Telecare			
Lone worker monitoring	2	30 mins	60 mins
Schools Security	2	30 mins	60 mins
Smoke detector management	1	30 mins	30 mins
Location based systems	5	30 mins	150 mins
Video-based services	4	15 mins	60 mins

Table 6 estimates the time required to handle the calls associated with each of the applications described above. Again, both the number of incidents and the time spent per incident are estimates, but appear to be reasonable based on existing evidence. It may be observed that smoke detector management, access management and domiciliary care monitoring all take about half an hour per service user per annum, similar to the time spent on dealing with basic community alarm users. As the level of alarm sophistication increases then the annual incident time increases to an hour; this is the estimated time for alarm telecare and applications in school security, lone worker monitoring and the delivery of video-based services. Lifestyle

monitoring and locating people through GPS are each likely to take 2.5 hours per service user per annum. This leaves telehealth services (i.e. remote monitoring of vital signs data) requiring 5 hours per patient per annum and proactive calling, though dependent on the number of calls per week, requiring about 17 hours of call handler time per annum.

Finally, before being in a position to estimate the additional human resource requirements for alarm handling, we need to understand the nature and timing of interventions. Although accidents might appear to be random incidents, they do not occur at random times of the day – thus demand for alarm services suffers a number of peaks and troughs through the day and night. Many of these are related to the times at which people perform the activities of daily living. Obviously, accidents in the kitchen involving overheating and incidents with the cooker tend to occur at mealtimes. Falls are more likely to occur during the hours of darkness. However, the situation is more complex than this implies, because alarm calls only happen if:

- there is no carer close by who can help; or
- if the accident is recognised and the person is able to manually raise the alarm through pressing on a panic button or pulling a cord.

Consequently, many alarm calls are made when an emergency is discovered rather than when the incidents actually occur. Peak times therefore correspond to when carers or wardens arrive at properties. The situation changes with telecare because the equipment can raise alarms automatically and independently of the user having to make a decision that they need help.

Figure 13 shows the alarm call rates (per 2,500 connections) hour by hour for a 24 hour weekday period in September 2006 for West Lothian and the six counties of North Wales.

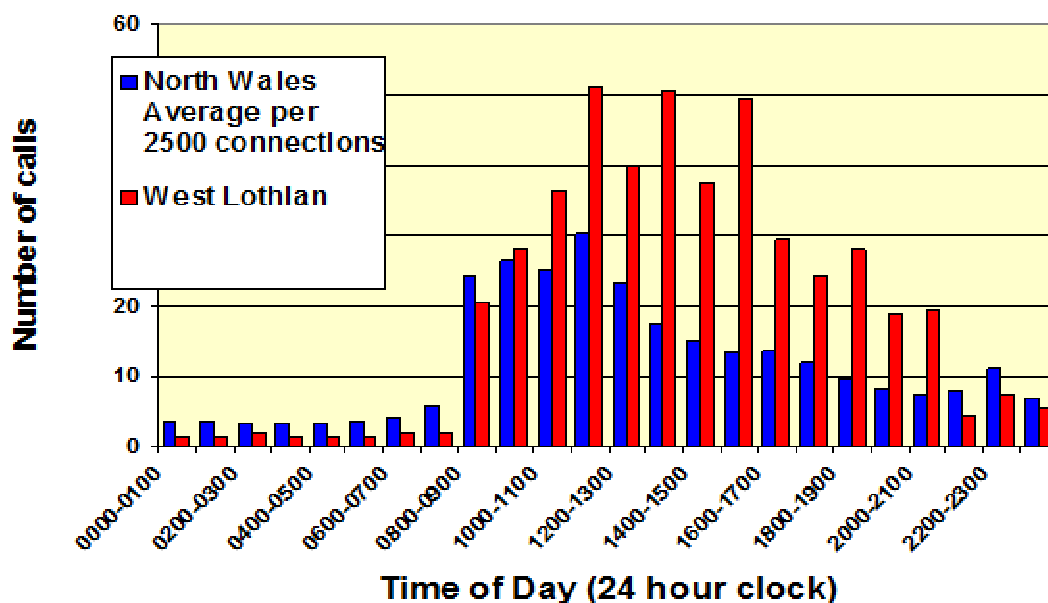

Figure 13. Alarm Call Patterns in West Lothian compared with North Wales.

The significance of the two different locations is that all of the monitored properties in West Lothian have telecare services (minimum of Lifeline 4000+, pendant alarm, smoke detector, movement detector, temperature extremes device and flood detector), with some 14% having enhanced packages which include fall detectors and equipment designed to support people with greater risks. In North Wales at that time there was no telecare service offered i.e. all service users had only a basic community/social alarm. There are a number of differences that are evident:

- the alarm volume for telecare is about 50% higher than with social alarms;
- the peak in alarm activity with telecare has moved from the morning-lunch-time to the early afternoon;
- calls at night are reduced by telecare by a factor of two or more.

The reasons why the number of calls at night are reduced by telecare is not obvious, but it could be that problems are detected sooner, and interventions are made during the evening in order to avoid emergencies at night. However, a consequence is that the night time provision, which is already extremely costly in terms of staff per incident, becomes even more expensive.

It follows that the capacity of call handling centres to accept even a modest increase in activity may be compromised unless there is investment in additional staff. Deciding when these extra staff should be employed will depend on the particular time-of-day requirements for each of the new telecare services. It is therefore impossible to be definitive in suggesting new general staffing levels. Individual partnerships may choose to add new services slowly in order to gauge how well they can cope with the extra demands of service provision, but clear need for review as they are implemented.

5.2 Financial Issues

Call handling is an important component of a telecare service. In order to consider the costs and income for the alarm handling centre, it is necessary to look in detail at all the costs and the potential business revenues (and how they might change over a 5 to 10 year period). We therefore present information on the added value for each type of service, together with cost effectiveness in *Appendix 8.4.1*.

5.3 Quality & Resource Issues

5.3.1 Service Specifications & The Quality Agenda

A telecare service specification is essential in order to define (amongst other things) the scope of the service, how it is to be realised and the desired level of quality and performance. A service specification becomes increasingly important when a telecare service is to be provided through a collaboration between separate service provider units. This is relevant to all aspects of providing a telecare service but usually involves three key stakeholders:

- The Service Commissioner;
- The Service Provider;
- The Call-Handling Centre.

The relationship between these entities can vary:

- They may all be part of the same organisation (e.g. a local authority with its own in-house telecare service and monitoring centre);
- The service commissioner may provide all elements of telecare service delivery except for the call-handling service, which may be outsourced to a centre run by a local authority, a housing association or a National provider;
- The service provider might offer the complete telecare service including the call-handling; or
- The commissioner may outsource the call handling and other elements of the service to several different provider organisations, requiring them to work together to produce an integrated service.

Service specifications can therefore be used as the basis for a service level agreement between service commissioners and providers as well as between providers themselves. The focus of this report is on call-handling, and takes the viewpoint of the telecare call handling centre (and that of their 'customers'); there are a number of key roles that need to be performed and which may need to be specified. These cover functional, procedural, technical, and charging issues, i.e. what services are provided; how they are implemented and how much they cost. So for *core* services the following details might be included in a service specification:

The type of services provided - including:

- **Monitoring Services Provided** – Community alarm, telecare, lifestyle monitoring, telehealth, lone worker monitoring, etc.
- **Other telephony-based call-handling** – out of ours housing repairs, street light problem reporting , etc.
- **Proactive calling services** – check calls for people discharged from hospital, computer assisted telephone interviews, etc
- **Alarm call handling** – can the call-handling system reliably decode alarm code meanings from equipment in the home, both older warden call systems and newer units used with the latest sensors? How many staff are on duty, and available, at all times? How quickly do they answer the alarm call? What are the language options available?

- **Remote programming** – can the call-handling system remotely configure or change the operating parameters of all field-equipment? Is this a vendor claim or something that has been tested with field equipment?
- **Response protocols & co-ordination** – defines how the service reacts to particular alarms and circumstances and how it co-ordinates the most appropriate response – including escalation and follow-up procedures; these may be specified by the commissioner/service provider and may need to be specific to the service user under certain circumstances.
- **Access** – the centre may be responsible for enabling timely access through the use of key-management, key-safe access code dissemination, caller identification and/or verification, or remote access using technology;
- **Client Database** – stores information on all service users, and allows managers to perform queries.
- **Performance management** – is central to the process of defining performance of the call handling service in terms of call waiting, response times, etc.
- **Data Backup & Security** - Does the service have an adequate data backup and security policy and procedures? Who is able to access the data and how is it controlled? How often is data backed up and how?
- **Service Contingency** –Can the service cope with or have arrangements to mitigate the effects of technical problems such as power-cuts or telecommunications network outages, or staffing problems due to illness or absence? Is there an on-site backup terminal? Do they have reciprocal arrangements in place with other call-handling centres? How long would it take for the service to switch over to an alternative arrangement?
- **Charging** – how much does the centre charge to provide particular services? How long will the charges be kept at these levels?

Of course, a specification is only an ideal – the actual performance of the call-handling service must be measured in order to establish whether it is meeting its specification. This usually involves the regular monitoring of key performance indicators, which may be strategic or procedural and requires regular internal audit. Ultimately an external audit or evaluation should be commissioned in order that an independent analysis is undertaken and so that the performance of the service can be compared with similar operations elsewhere as part of a benchmarking process to identify areas that are performing well, in addition to those that require improvement.

The questions which naturally arise are: “*what makes a good service (specification)?*” and “*what represents best practice across the industry?*” These are currently difficult to determine,

partly because services are still evolving but also because no standard framework has been in place to evaluate and benchmark services. This makes it difficult to compare the output of different evaluations as each may be monitoring different aspects of a service or measuring them in different ways. Thus, it is difficult to know if benchmarking comparisons are truly comparing like-for-like. A multi-domain evaluation framework has been proposed for telecare by the current authors^[26] and has been applied successfully in a number of locations across the UK. The need for a standard approach such as this may be apparent, and may eventually lead to a method of successfully benchmarking services in order to help identify areas of best practice.

In terms of a national 'golden' standard, the Telecare Services Association (TSA) codes of practice offer the only industry standard accreditation for telecare & community alarm services. The codes of practice have consisted of three parts (but are undergoing a review and rewriting process during 2007/8):

- Part One – Telecare Calls Handling Operational Requirements;
- Part Two – Telecare Installation Operational Requirements; and
- Part Three – Mobile Response Operational Requirements.

Part One has been agreed as the applicable technical standard (for call handling services) in respect of Supporting People in England; the TSA is also working with the devolved governments elsewhere in the UK with a view to their adopting the Code as the appropriate standard for community alarms, and ultimately telecare. Currently, only 3 call-handling centres in Scotland have achieved Part 1 accreditation^[36]. To become fully compliant with the TSA's codes of practice, organisations must achieve accreditation against the *Strategic Framework* as well as *each* of the operational requirements for the service areas that are being provided (i.e. monitoring, installation and response). The strategic framework addresses issues related to individual rights and empowerment, care and support, organisation & management as well as staffing and training issues. Accreditation with these codes of practice provides an independent 'endorsement' of the service. For monitoring centres in particular, accreditation with Part 1 may increasingly be deemed as strategically important if it wishes to attract monitoring business from other corporate customers, as they are more likely to seek service providers who are TSA compliant. However, in the opinion of the authors, the current framework no longer guarantees the delivery of the highest quality telecare services that are consistent with the aspirations of forward-looking directors and managers of care agencies. Consequently services should strive to achieve a rather higher service specification wherever possible.

The Codes of Practice were originally developed as measures of performance which could be audited to allow members to claim accreditation in call handling, installation or response services respectively for the very limited range of applications involved with community

alarms. Although many TSA members have been quick to move from community alarms into telecare, they were collectively slow to recognise that the practices that were being employed were not consistent with the service specifications required by social work departments and by primary care organisations who are becoming the commissioners of telecare services. The Codes of Practice are acknowledged by TSA to be out of date. Consequently, they, and the accompanying guides to best practice, are being rewritten by external experts so that they might more consistently match the future needs of the commissioners. There can be no guarantee that they will identify all examples of best practice as most services have yet to be audited from a broad telecare perspective. They are due to be re-issued in late 2008 and are intended to be updated on an annual basis to include changes in operational performance due to technological developments which continue at a high pace.

5.3.2 Staff Roles, Profile & Training

It may be apparent from the previous discussion on service types that the staff profile (and subsequent training requirements) of a telecare monitoring centre will depend on:

- the range of services offered;
- the roles and responsibilities of monitoring centre staff (i.e. in addition to call-handling); and
- how the roles are allocated across available staff.

Additional roles sometimes adopted by alarm handling staff include:

- performing assessments, and identifying required equipment;
- installation and testing of equipment; and
- responding to emergency events in the community.

In these cases, the staffing model adopted can range from each role being performed by dedicated 'specialists' or having generic staff who are capable of performing many or all of the roles as required. Each approach has its own advantages and disadvantages. The latter has advantages in allowing staff to work flexibly in order to cover all the required operational functions. This minimises disruptions caused by illness and holidays, allowing agency staff to be brought in to perform tasks which may require the minimum learning time. However, it means that staff members can take several weeks (or even months) to become competent and confident in some important functions. The cost of training is also much higher than it would be if individual staff members were trained as specialists in particular skills such as call handling or installations. It follows that the requirements for some tasks can reduce the number of suitable applicants. For example, a responder and an installer need to be able to drive in order to get to the premises of service users quickly; they also need to be checked by the police because they are required to enter the premises of vulnerable people. Responders

need to be trained in First Aid and Manual Handling techniques, while installers need training in use of ladders, and power tools as well as in the identification and procedures for dealing with asbestos. Both groups need to be mobile as they may have to climb several flights of stairs.

On the other hand, call handlers may be recruited because of their negotiation skills, their telephone manner, and their ability to remain cool in a crisis. They may have a long term condition or a physical disability that would make tasks outside the office impossible for them to perform. A policy of employing people only for a limited range of tasks might then enable organisations to better meeting their obligations under the Disability Discrimination Act (1995).

In the future, as cases become more complex, training will need to be improved and increased, so the matching of person to job may become more important. It is highly likely that assessors will become limited in their prescriptions by their own confidence in the latest devices. Keeping potentially large numbers of staff trained to the same level will be extremely difficult and may lead to variations in the level of service provided.

The need for high quality training is a theme which runs through all service provision, from general awareness (which provides a foundation upon which to build more specific expertise as required) to more specific modules on assessment and equipment prescription, installation, call handling & reporting and response. In each case, good training can be the difference between an excellent service and a poor one, which ultimately lets down service users.

From the viewpoint of the telecare monitoring centre, the scope and level of training required is related to the services that are offered and the roles performed by staff. Table 5 lists some of the training which might be required for call-centre staff. Training can be developed and provided by in-house teams/personnel but usually requires some form of external training in the first instance and as new services are introduced, it may be necessary to commission training from manufacturers or from specialist providers.

Most equipment manufacturers offer training on their own product range. Such courses will be appropriate for programming & installation as well as how to operate call-handling systems. Some have extended their training packages to include the processes involved in delivering a service. For example the Tunstall Telecare Training Tool, which has been accredited by the College of Occupational Therapists, includes sections on risk management, sensor placement and programming, as well as on clinical outcomes. However, such courses are likely to be limited or heavily influenced by the knowledge and product range of the equipment supplier in question. Hence, the Tunstall offering does not currently include aids and adaptations, electronic assistive technology, telehealth or environmental control systems as part of the overall training, though this may change as their product range matures.

Table 5. Training requirements for call-handling services.

Call-Handling Training Requirements	
<ul style="list-style-type: none"> • Telecare awareness training • Call-handling using the telecare alarm call-handling software. • Specialist telephone-based operating techniques (such as the correct use of greetings, relating with people over the telephone, dealing with difficult situations/complaints, conflict resolution, etc.) • Response protocols, co-ordination and non-standard call-handling response protocols. 	<ul style="list-style-type: none"> • Dealing with people with communication difficulties. • Dealing with people with learning difficulties. • Dealing with people with Dementia/Mental health problems. • Management report & Data Auditing functionality of the telecare alarm monitoring software. • Data Protection.
Additional Training Requirements (depending on staff roles and responsibilities)	
<ul style="list-style-type: none"> • Operating telehealth software. • Response protocols for telehealth. • Operating lifestyle monitoring software. • Response protocols for lifestyle monitoring alerts • Installation/Programming of telecare equipment. • Basic Maintenance and Cleansing of field equipment. 	<ul style="list-style-type: none"> • Assessing the needs/risks of service users. • Matching telecare equipment to identified needs/risks. • Health & Safety. • Asbestos awareness. • First-Aid. • Risk assessment. • Manual Handling. • Specialist lifting equipment (e.g. Mangar ELK, CAMEL). • Use of ladders. • Use of Automatic Electronic Defibrillators (AED)

Organisations such as the Disabled Living Foundation also sometimes offer courses related to telecare. One such offering is a course entitled “*Telecare Solutions and Assessment of Service Users*” – this is provided by an occupational therapist who claims specialisation in electronic assistive technology and telecare. Such courses may however be provided infrequently (e.g. once every 6 months) and may be provided in a certain geographical location. A more flexible approach may be provided by the range of specialist consultancies that exist, many of which offer training as part of their portfolio of services. However, these generally lack the technical expertise necessary for detailed training. They can also lack the vision needed to prepare for the future and to understand the research agenda.

Educational establishments have been slow to provide accredited training in telecare-related topics, perhaps because it spans a wide number of fields, ranging from care through to information and communications technologies. In most developed areas of community care, there are accredited training courses with GNVQ or City and Guilds qualifications available for those achieving the required standard. Colleges and universities are only now offering modules in electronic assistive technology, with telecare being only a minor component (except for the pioneering work performed at Lothian College in partnership with the local authority). Consequently, training courses and events are being offered by organisations and/or

individuals who may lack either the technical expertise necessary to understand practical issues, or the clinical reasoning to ensure that solutions are appropriate, or who rely totally on third parties to provide both content and delivery of the courses.

One course, which does appear to be designed specifically for call-handlers in a community alarm/telecare environment is offered by the Centre for Sheltered Housing Studies based in Worcester but with academic links with Cornwall College. Their courses are aimed at housing providers, and especially the wardens who provide visiting and management of sheltered housing schemes. Their experience with telecare is with the environmental alarms rather than with the social or medical forms of telecare. Their course for call and control centre operators (which *appears* to be based on a the 'Call and Control Centres' pathway from the Chartered Institute of Housing's Level 3 national certificate in Housing^{viii}) includes the following topics:

- The context of call and control centres;
- Customer care;
- People and professional skills;
- Meeting the needs of service users;
- Control centre technology and the potential future role of control centres; and
- Professional development.

Ideally, there should be a national body with responsibility for accrediting such courses. The Telecare Services Association (TSA) hopes to assume responsibility for training in 2008 and beyond. However, the association has traditionally had two member groups, the suppliers of equipment, and the organisations (mainly housing based community alarm monitoring centres) which use the equipment to provide the service. Currently, many existing training courses have been provided, supported or sponsored by telecare equipment vendors. In the future, it is unlikely that a single company will offer the spectrum of telecare from stand-alone equipment through smart sensors to lifestyle, vital signs and activity monitoring, as well as automatic responses including shut-off valves, smart lighting and the playing of recorded messages. Thus, training for assessment, prescription and all aspects of response may be flavoured by the capabilities of the equipment supplied by that vendor, and will be deficient in technologies provided by third parties. With the vendors also exerting influence on the TSA, the independence of accreditation may lack credibility.

It follows that most training will need to be developed locally and delivered both initially and in the future using in-house resources. Responsibilities for training need to be embedded within

^{viii} <http://www.cih.org/education/level3-9.htm>

the job descriptions of some members of the telecare team. Estimated costs for each training element are shown in Table 6 based on a typical local authority with a population of about 150,000.

Table 6. Costs and Resources for Training.

Type of Training	For Which Groups	Resource Requirement	Likely Cost	Other Options
Awareness	All H&SC staff, carers, domiciliary care staff, nurses, therapists	Approx 3 hour sessions for up to 25 people at a time, repeated every 6 months	£600 p.a.	Vendors may offer free courses – but only to deal with telecare that they supply
Installation	Installation staff, Care & Repair, local electrical & telecoms company staff	Manufacturer’s accredited training	£500 per day per company (£2000 p.a.)	Share costs with other local authorities
FAQs	Service users, family, friends	Leaflets and item descriptions for care plan packs	£3000 for writing plus £2000 for printing	Demand end-user documentation from vendors
Assessment & prescription	Care managers, specialist assessors	Training manual, regular updates, day courses for small groups	£3000 for manual; £2000 p.a. for courses	Link with other partnerships across Scotland to share costs
Call handling & reporting	All call-handling staff	Advanced procedures manual; technical and procedural courses for staff	£2000 for manual; £800p.a. for courses	Outsource monitoring to another organisation
Response	Response team plus representatives of emergency services and reablement teams	Full training sessions to include Health and Safety, manual handling,	£2000 p.a.	Employ only staff already working for local authority, health board or NHS Trust

It follows from the above that training can be a costly and resource-intensive element of service provision. Costs can be reduced by standardisation wherever possible and by limiting the number of suppliers. Although this may limit the choice available to individual prescribers, this is rarely an issue providing the major suppliers have access to the largest range of equipment. Standardisation should therefore be relatively simple in the short term. Over the medium to long term, greater interoperability between equipment supplied by different vendors will be inevitable, and standardisation will be possible without compromising choice in the vast majority of cases.

5.3.3 The Cost of Monitoring Quality

A quality service will have a good specification, state of the art equipment, efficient procedures and operating protocols and well trained and motivated staff. Such a service will also want to prove that it is providing a quality service by obtaining accreditation with the TSA codes of practice and through external audit and evaluation. However, this commitment to quality comes at a price.

The process of attaining accreditation can be a lengthy affair, depending on how far away the service is from the required standard and on how many of the codes the service wishes to be accredited against. In the first instance, the service must undertake a pre-audit assessment in order to establish the work that will need to be undertaken to get to the point where accreditation may be tested. The TSA offers a pre-audit inspection which can establish an organisation's readiness for compliance to assist in this process. The work necessary to get a service up to the necessary standard usually takes between 3 and 6 months. Typically a member of staff can be seconded to the task but it can also be outsourced to a consultancy firm that specialises in such matters. To achieve compliance, organisations must undergo a rigorous initial audit with annual maintenance inspections. On every third anniversary of the initial audit, the service provider will be required to undergo a full audit to ensure that they remain fully compatible with the currently applicable version of the Codes of Practice. Assuming call-handling only (i.e. Part 1), then the cost might be (based on 2007 prices):

- Membership (£914)
- Optional pre-audit inspection (~£500)
- Pre-audit work (~£7,500)
- Staff training (~£5000 – for full – will look up for partial)
- Initial Audit (~£1000)
- Annual maintenance inspections (~£600)
- Tri-annual full audit (~£1000)

Thus, the costs in the first year would be in the order of £15K. Over a 5 year period then the total costs would be:

- Year 1 – membership + compliance = 15K
- Year 2 – membership + annual inspection ~ £1,500
- Year 3 – membership + annual inspection ~£1,500
- Year 4 – membership + full inspection ~ £2,000
- Year 5 – membership + annual inspection ~£1,500

- Total over 5 years (with no increases in membership and fees) ~ £21.5K
- For Scotland, with 22 partnership-run monitoring centres (in addition to the Hanover and Bield centres), the cost for accreditation with Part 1 only would be ~ £475K.

In addition to accreditation, services may occasionally wish to commission an evaluation of their service. Reviews involve comparing performance against realistic targets every week, month or year for referrals, assessments, installations, and withdrawals, together with the accurate recording and reporting of outcomes. It is essential that the results and recommendations that are obtained through a service evaluation and audit of performance are credible and are taken seriously by all parties. Thus, it is important that an independent approach is taken. Hence, this work should be performed by an external body (e.g. consultants) with specific expertise in both the technologies and the service. A simple audit of processes and procedures may be performed over the timeframe of a month and could cost something in the region of between £5K - £7K. This would represent good value for money only if it identified areas for improvement and opportunities for improving business opportunities. This may become unnecessary if Scotland introduced its own strategy for accreditation and performance monitoring.

A more comprehensive evaluation which might include more emphasis on outcomes and impact might take a little longer. The outcomes include the number of incidents such as alarm calls and their causes, together with the speed of response, the result of the intervention, and the likely effect of not having a telecare service in place. Outcomes should also include longer term effects including the ability of an individual with telecare support to return home from hospital sooner following illness or injury, and any reduction in demand for residential home places. Such an evaluation might cost somewhere in the region of £12K - £20K depending on its scope and could be part of a national service bench-marking strategy.

An increasing burden of performance monitoring and evaluation based more often on outcomes as well as basic operating statistics will mean that the demand for data analysis will increase. This may require that a member of staff is charged with the role of 'internal data auditor/analyst' who should be responsible for ensuring that the correct data is being collected and collating it using automatic reporting facilities, where possible, into a form that is suitable for supporting the evaluation process.

5.3.4 Monitoring Centre Premises & Support

The premises in which a telecare monitoring centre operates are an important factor to consider when discussing how call-handling services may evolve. Telecare monitoring centres are typically situated in a number of different premises, including:

- Purpose-built modern office facility;

- Co-located with other call-centre operation(s);
- An office or unit in a sheltered housing scheme;
- An ordinary property (house or flat)

The TSA codes of practice currently include consideration of the physical structure and layout of a telecare call-handling centre. These refer to issues such as health & safety, centre access, data protection and business continuity. Centres must also possess the necessary infrastructure (e.g. ventilation, power supplies, telecommunications, computer networking, fire and staff protection systems, etc.) to ensure that the service can operate reliably and help provide a safe and healthy environment for staff. Functionally, the centre must provide an environment in which call-handling can take place in a comfortable manner where client data cannot be viewed by unauthorised personnel. If the centre also provides other services, such as equipment programming & testing, equipment cleansing & storage, then additional work areas and equipment will be required. If the centre is also used as a local equipment store, then suitable space must also be available to hold a sufficient level of stock of an increasing inventory of equipment. Likewise, if the centre also provides response services, then it may also require space to store additional items of equipment.

There are 4 different models for call handling services currently operating in Scotland; these include:

- Small local centres serving only local communities (but which also provide telephone support for other council services such as lone worker protection and out-of-hours reporting of problems with housing, etc.);
- Medium-sized regional centres servicing between 2 and 8 neighbouring authorities;
- Large centres serving large areas of population (i.e. big cities); and
- Housing associations which provide services for their own tenants, for some local authorities and for a wider dispersed audience including private payers

A fifth model is emerging in South Wales (e.g. Vale of Glamorgan) where local authority contact centres have incorporated many social services referral functions, and are now also operating their community alarm and telecare services. In North Wales, a similar review also concluded that small centres were not viable and that regional monitoring centres supporting local telecare delivery teams was the most cost-effective and future-proofed option. A plan to merge 4 monitoring centres is currently being implemented, though it should be emphasised that the proposed model involves building local telecare service capability in each of the six counties in order to utilise the opportunity afforded by sharing one high quality alarm handling centre^[27].

The staffing profile and subsequent training requirements for a telecare monitoring centre will vary depending on its size and the role that it performs within the overall telecare service. A centre that offers monitoring only will require call-handling staff and training related to call-handling only, whereas a centre that also offers installation, response as well as basic maintenance and equipment storage will require staff with a broader range of skills and training as well as an area to clean and store equipment. When call-handling services are sub-contracted out, then it is important to consider the additional roles that the existing service may be providing – and how these will be realised.

Centres that offer additional types of telecare are more likely to feel involved with the telecare service and act as the hub of a local telecare service, providing the integration element and will more likely possess the necessary culture to accept new service types, technologies and to generally drive the service forward. As the number and complexity of the systems (lifestyle monitoring, telehealth, video-based services) installed in the call-handling centres increases and as the move to IP-based services increases (leading ultimately to an IP-based centre), more and more of the functionality of the centre will become software-based. This requires that the computers, soft phones, servers, networks, software, etc. need to be under the constant supervision of an ICT maintenance manager whose role – whether outsourced or not – is critical to the effectiveness of the telecare operation. Issues such as data backup and business continuity become more important.

5.3.5 Marketing and Other Management Issues

In order to grow a telecare service, it is important that suitable service users are recruited as soon as possible. This may involve trying to move existing community alarm service users onto services with higher added value, or finding, through effective marketing, a whole new raft of potential service users who previously weren't aware of telecare, or who will recognise the significance of one of the new propositions.

Increasing the number of appropriate referrals requires a combination of awareness training (for staff) and publicity and promotional materials (for staff and potential service users/families). The latter might include advertising using local media (papers, radio, local hospitals/GP surgeries, council tax flyers, etc.). The use of demonstration flats or 'smart homes' are a popular means to raise awareness of the potential of telecare – these allow people to view equipment in a pseudo-real environment. The use of the internet should be considered with a dedicated website providing details on various aspects of the service, for example: what telecare is, what equipment is available, how to get referred, eligibility criteria, pricing, response services, complaints procedures, performance measures, etc. It should also be relatively easy to find from the home-page of the council's website. On-line assessment or referral is likely to become increasingly popular. Self-referrals might be supported by a formal self-assessment form which can be used to signpost individuals to the most appropriate

contact/service provider based on their needs and circumstances. One way of facilitating this might be via the web-site, which could ask a series of questions to ascertain quickly whether the needs and circumstances of the client were well-suited to the telecare service on offer. Current examples include Philips Lifeline, who employ a nine question web-based questionnaire to point potential service users in the right direction; Kent who use it for their social services and Gwynedd Telecare's service who use a system to help third party organisations to identify people who might benefit from a telecare service.

From the viewpoint of the telecare monitoring centre, whether it is integral to the telecare service or at its periphery, its future depends on the income it can obtain through providing a service to service users (either locally or to other areas). In order to maximise the number of connections, it is imperative that the local service is promoted and marketed well, and, if it is looking at winning business from other areas, then it is important that it has its own marketing strategy and business plan.

The biggest call handling centres will have a management structure which includes separate people with responsibilities for new business development, marketing, operations, research, and quality assurance. For smaller centres, there may only be one or two management posts which means that individuals will be required to cover many different roles. This may result in general weaknesses in performance management across the board.

5.3.6 Alternative Models to Community Alarms

There are a number of potential alternative providers of telecare call-handling services, including:

- **Council run generic contact centres** – With this approach, there is a need to consider how services are integrated so that an appropriate response to an alarm is obtained in all cases. The traditional call-centre 'culture' is likely to be one of achieving a high turn-over of calls in the shortest possible time. However, telecare requires particular skills to elicit information from the client and to establish the exact nature of the problem and therefore what the most appropriate response should be. The operating model in such situations may be either an integrated call centre arrangement where all call-handlers answer all calls on-demand or it may simply be a co-location of facilities where the two distinct functions are separated functionally within the same building/room. Several areas are developing centres which perform both council contact centre roles and that of telecare call handling. The latest versions of call handling system encourage call-type/skills-based routing which would allow maximum staff flexibility whilst ensuring that the most skilled person receives an alarm call. However, it should be cautioned that a Hanover (England) project to merge its community alarm handling operations with a more general corporate call centres ended in failure.

- **Housing Association control centres** - These are call-centres run by housing associations mainly on behalf of their own tenants. They might already provide alarm call handling services to their own tenants and to some partnerships. They generally have strong management structures, clear business objectives and appropriate IT and HR support to enable them to expand their operations so that they can offer either a regional service or a national service.
- **Private National Centres** – These are call centres that offer a service to all of the UK. They typically have many call-handlers on duty at any one time and are able to charge very low rates due to economies of scale (having as they do many ten's of thousands of service users). For example, in the UK, Tunstall Response's monitoring centre in Doncaster services ~120,000 connections and handles ~2 million calls per annum. In the United States, Philips Lifeline have just one or two call centres which service over 500,000 service users who generate 7.5 million alarm calls per annum. As a consequence, organisations such as Tunstall Response can offer prices of 25p per connection per week for basic monitoring. However, larger centres run on a commercial footing are bound to be pressured into increasing throughput meaning that the quality of service provided must come under pressure. Quality of service therefore needs to be specified in the SLA as well as price. Furthermore, as the number of customers for large centres increases, it is likely to become increasingly difficult for operators to follow individual response procedures which may be different for different service providers (even though they may be displayed on-screen). The local touch and knowledge is also lost as well as the ability to use call centre staff to perform functions such as maintenance, cleaning, pre-programming/testing units and for the centre to act as an equipment store. The above issues have been raised as a matter of concern by alarm handling centre managers, and similar issues have been identified in Wales and in the North and South West of England, as well as in the Midlands. They have not been addressed in any formal research at this time.

Alternative providers for monitoring (telecare and/or telehealth) may include:

- | | | |
|------------------------|------------------------|------------------------|
| • Tunstall Response. | • Broomwell | • TBS GB |
| • Chubb Community Care | • Docobo | • Vivatec |
| • Age Concern | • Philips Medical | • Wealden & Eastbourne |
| • Fold Telecare | • RSL Steeper | |
| • Invicta | • Seniorlink Eldercare | |

- **NHS-24** - is an online and telephone-based service for answering questions and offering advice about health-related matters. The telephone-based service is essentially a telephone triage service based on computer based telephone triage software that uses algorithms to assist the operator to handle the call appropriately. It consists of a non-clinical triage stage to establish the reason for the call and a clinical triage stage which is provided by a nurse (nurse advisor) or pharmacist, or similar. They will provide advice, refer on to another service (e.g. GP) or arrange for an ambulance. There are 3 main contact centres – East (South Queensferry), North (Aberdeen) and West (Clydebank). In addition, there are 5 local centres in partnership with NHS boards (Ayrshire & Arran, Highlands & Islands, Tayside, Lanarkshire and Dumfries & Galloway). The non-clinical call-handlers use 'advise and refer' service protocols to allow them to take calls with specific presenting symptoms – reducing the demand on the nurse advisors.

NHS-24 are looking to expand their range of services (currently focussed around providing information and out of hours call handling). With the move to telehealth and the probable increase in the need for telephone-based clinical and non-clinical triage, it may be argued that NHS-24 could move into the telehealthcare call-handling market. However, an analysis of NHS Direct in England showed that it costs ~ £16 per call. In order to provide this expanded role, they would need to consider issues of capacity very seriously, and also invest in appropriate telecare alarm receiving systems capable of accepting ALL rather than most alarms generated in the community. The West Yorkshire Monitoring and Ambulance Service (WYMAS) attempted this integration during the early years of this decade but have subsequently pulled back. NHS Direct in London is also proposed as a partner in the Whole System Demonstrator roll-out in Newham, but the exact role and charging structures are not yet in the public domain.

The option of Local Health Boards or Trusts attempting to combine the Birmingham OwnHealth model with lower level support needs including handling of telecare calls cannot be discounted at this time. Telephone call handling staff for this model of provision have traditionally been trained nurses. Using skills based routing technology, it is possible to ensure that calls are directed to the member of staff who is most appropriately trained to deal with such a call. This opens up a possibility of having a mixture of staff in the monitoring centre, so that all types of call can be dealt with.

6. Models for Future Alarm Handing Centres

6.1 Matching services to capabilities, compatibilities and vision

Telecare services are already changing in response to a number of different drivers. Perhaps improvements in technology will become the dominant factor as limitations of size, processing

power and communications bandwidth disappear within the next 5 years. This will encourage the development of more intelligent devices within the home, and decrease the need to have a “human in the loop” when responding to identified problems. In the same way, ubiquitous computing and access to the internet through interfaces provided in white goods such as refrigerators (see Figure 15), as well as through set top boxes (see Figure 14) will encourage people to set up and program telecare systems remotely. The need for an alarm handling centre might therefore be compromised.

However, the experience of the population with distant call centres has not been positive. They are only tolerated for service applications because they provide a low-cost solution. There is no evidence to suggest that the Scottish public is prepared to accept either a call-centre culture when it comes to issues of care or life or death situations. Most older people have made it clear that they want to know that there will be a real person available to answer their calls, day or night, and that person should be in Scotland. No research appears to have been done to determine whether the call handler needs to be local (and this might mean a distance of over 100 miles in some areas), regional (and this could mean 2 or 3 local authority areas or 9 or 10), or national. Hence, all these models exist and there are currently no objective measures available to compare their cost-effectiveness, their efficiency, their performances, or their satisfaction ratings.

It may be apparent that the existing alarm handling centres will each face different challenges in preparing to move forward with the telecare agenda. The model of service that they represent may be compromised by any or all of the drivers described above. Their financial viability will then come under scrutiny as elected members and senior officers of partnerships consider the investment required to provide new services, as well as the other resources needed to ensure that they operate at the required standards. The following sections examine in more detail the options that face existing partnerships in planning for the future.

6.2 Small single authority

Tables 7 and 8 describe the advantages and disadvantages of an existing authority with fewer than 3,000 connections. Three options may be offered, the status quo, combining with neighbouring authorities into a regional group, and externalising alarm call handling to a national centre.

Table 7. Advantages of call handling options for a small authority with its own call handling arrangement.

ADVANTAGES		
Status Quo	Regional Centre	National Centre
<ul style="list-style-type: none"> • Minimises disruption • Avoids costs associated with change • Offers local end to end service opportunity • Benefits from local knowledge of staff • Many processes and procedures are already developed • Enables closer working with health boards on local agendas/priorities • Easier for small organisation to coordinate services 	<ul style="list-style-type: none"> • Reduces operating costs • New arrangement encourages a "Centre of excellence" mentality • Standardised approach encourages joint working • Easier to introduce new services • Focuses expertise • Can help drive forward telecare agenda • More effective use of human resource • United centre is a stronger business entity • Easier to meet TSA codes of practice • Big enough to operate most new services • Can forge links with regional centres in research and in service development • Model already in existence in Scotland 	<ul style="list-style-type: none"> • Opportunity to link with industry for product design and testing • Lowest cost base and economies of scale • Able to offer specialist services for dealing with complex cases • Probably provides access to all relevant services • May provide training courses modules as industry leader • Quality of service delivery likely to be assured • Access to adequate IT and management support • No capital needed to buy into service • Already being used successfully in Scotland by some local authorities

Table 8. Disadvantages of call handling options for a small authority with its own call handling arrangement.

DISADVANTAGES		
Status Quo	Regional Centre	National Centre
<ul style="list-style-type: none"> • Shortage of technical expertise • Difficult to achieve industry accreditation standards • High fixed costs • Small numbers of service users limit opportunities for winning income from individuals • Difficult to gain investment for service development • Premises often unsuitable for expansion • Limited scope for new developments • More difficult to standardise services • Difficult to recruit suitably qualified staff • Big training programme needed • Small budget for marketing 	<ul style="list-style-type: none"> • Reduces some element of individual choice • Compromises existing investments in equipment • Removes an element of local service delivery • Little redundancy in the system • Not necessarily compatible with all existing services • Change may be costly • Potentially complex management & governance issues to resolve • Problems in developing service until strategies are harmonised • Must overcome opposition by some elected members • Difficult to enter an existing partnership on equal terms 	<ul style="list-style-type: none"> • Little choice available for provider service • Removes local control over key area of service delivery • Lose direct contact with service users • May need to accept protocols of other organisations • High risk of some equipment incompatibilities • Service name may not include that of the local authority

DISADVANTAGES		
Status Quo	Regional Centre	National Centre
<ul style="list-style-type: none"> • Service threatened by key worker illness/holidays/maternity leave • Future voluntary stock transfers to a housing association may compromise viability of service • Small centres lead to weak management structures 		

It may be observed that there are many and significant reasons for such authorities to abandon the status quo and to employ alternative models of call handling centre. The major problems that the small centres face are those of cost and the need for investment in both equipment and in human resources in order to achieve high quality standards in all aspects of service delivery. The development of new telecare applications, and the likelihood that service users in the future will expect more, but will also be older and in need of more support, places an onus on the centre to become a significant cog in the wheel of telecare. Local partnerships will need to consider the scope of provision that will be possible through their existing centres and accept the need to outsource some services to other providers.

It should be noted that neither entering a regionalisation arrangement, nor employing a national alarm call handling centre, means the closure of an existing facility. One option that has become popular in some parts of Wales, is the idea of operating a local call handling centre only on weekdays and from 8am to 8pm with the remaining hours being outsourced; this reduces the number of hours of business per week from 168 down to 60 which results in major cost savings. This requires compatibility of equipment across the two centres, but modern call handling equipment (such as PNC5) is designed to encourage this mode of operation. An extension of this arrangement would be for different local partnerships to take it in turns to provide the out-of-hours provision. Such an arrangement may be ideally suited to groups of 4 partnerships which would mean night and weekend working only once a month for staff. Of course, equipment compatibility issues will be compounded by the involvement of many centres.

The closure of a call handling centre does not necessarily imply redundancies. The local nature of many aspects of telecare services, including assessment/prescription, installation, withdrawal of equipment, maintenance and emergency response means that existing staff may be redeployed to provide a dedicated telecare workforce who can raise the local profile and improve the marketing and take-up of services. Provided that a local strategy and specification are in place, then change can bring significant opportunities for smaller authorities and partnerships.

6.3 Regional

Assuming that the new shared arrangements are already in place and offering an acceptable and cost-efficient alarm call handling facility, then existing users of such services may need to compare the status quo with a devolution back to their original arrangements, or a complete outsourcing to a national centre. Tables 9 & 10 compares such approaches.

It may be observed that there are significant advantages in maintaining the status quo unless there have been particular issues in harmonising approaches across all the partners in the regional centre. The disadvantages might all be overcome with appropriate attention to issues of ownership, responsibility and shared governance arrangements.

Table 9. Advantages of call handling options for partnerships using a regional alarm call handling centre.

ADVANTAGES		
Status Quo	Regional Centre	National Centre
<ul style="list-style-type: none"> • Minimises disruption • Sharing of operating costs already achieved • Cost savings have already been demonstrated • New arrangement encourages a "Centre of excellence" mentality • Standardised approach encourages joint working between neighbouring authorities • Shared processes and protocols already developed • Supports sharing of secondary care • Has sufficient service users to enable new services to be introduced more easily • Enables development of in-house technical expertise • Focus is already on telecare agenda • More effective use of human resource • United centre is a stronger business entity • Easier to meet TSA codes of practice • Big enough to operate most new services • Ready access to academia for consultancy & research • Promotional strategy already in place • Opportunities for working alongside other regional partnerships in bench-marking and disaster recovery 	<ul style="list-style-type: none"> • Offers local end to end service opportunity • Benefits from local knowledge of staff • Enables closer working with health boards on local agendas/priorities • Easier for small organisation to coordinate services • Politically attractive to elected members • Offers local identity to a local service • Encourages diversity and innovation 	<ul style="list-style-type: none"> • Further opportunities for reducing costs • Standardised approach encourages joint working across country • Easier to introduce new services • Focuses expertise in many diseases and conditions • Can help drive forward an advanced telecare agenda • More effective use of human resource • Allows introduction of specialist call handling staff including nurses • Easier to address training issues • Suitable call handling centres already exist

Table 10. Disadvantages of call handling options for partnerships currently using a regional alarm call handling centre.

DISADVANTAGES		
Status Quo	Regional Centre	National Centre
<ul style="list-style-type: none"> • Services haven't been running long-enough to be mature • "All eggs in one basket" • Potentially slow to respond to a local need • Ownership and control issues may arise • Requires agreement at all levels including basic equipment and vision • Becomes difficult to undo the structure the longer it goes on • May lack leadership over time as personalities change 	<ul style="list-style-type: none"> • Introduces variable standard of service • Moves away from standard and low cost approaches • Major set-up costs • On-going revenue costs are substantially increased • Local shortage of technical expertise • Need for new TSA accreditations • Need for new management structure • Need for new premises suitable for expansion • Little scope for new developments • Missed opportunity for developing wider partnerships and bringing skills together 	<ul style="list-style-type: none"> • Loss of control • Compromises existing investments in equipment • Moves control of telecare further away • Not necessarily compatible with existing services. • Costs may increase in future years • Limited by decisions taken centrally

6.4 Large city

Scotland's largest cities have existing alarm handling centres which have sufficient capacity to deal with most new and existing telecare applications. However, they might also have a very diverse range of equipment in use, and may be constrained in developing new applications by legacy issues. Tables 11 & 12 compare the option of staying with their current arrangement with that of outsourcing to a national centre.

Table 11. Advantages of call handling options for a large city.

Status Quo	National Centre
<ul style="list-style-type: none"> • Minimises disruption • Processes and protocols already in place for many applications • Unit costs already low due to economies of scale • Access to IT skills • Low recruitment problems • Close to primary and secondary care facilities and providers • Well-positioned for partnership development across wider community • No need to consider other partnership strategies when purchasing new equipment • No restrictions to developing new applications of telecare • Opportunities for working with other big cities • Big staff pool improves potential for flexible working 	<ul style="list-style-type: none"> • More opportunity for reducing costs • Standardised approach encourages joint working across country • Easier to introduce new services • Focuses expertise in many diseases and conditions • Can help drive forward an advanced telecare agenda • More effective use of human resource • Allows introduction of specialist call handling staff including nurses • Easier to address training issues • Suitable call handling centres already exist

Table 12. Disadvantages of call handling options for a large city.

Status Quo	National Centre
<ul style="list-style-type: none"> • All costs for new capital equipment must be borne by the city • Revenue costs aren't shared so potential for high operating costs • Highly dependent on tenants within sheltered housing • May miss opportunity for service review and improvement • May need to share resources with other corporate functions including CCTV monitoring 	<ul style="list-style-type: none"> • Loss of control • Compromises existing investments in equipment • Moves control of telecare further away • Not necessarily compatible with existing services. • Costs may increase in future years • Limited by decisions taken centrally • Political back-lash

It may be observed from the above that there are relatively few overall benefits in larger cities outsourcing their provision, providing that they each have a good vision for telecare service development, and are prepared to support these appropriately.

6.5 Virtual Alarm Handling Centre Options

This option is, in principle, an answer to some of the problems posed by the operation of small monitoring centres, as it allows organisations to move away from the location-based alarm-handling services of the past. Clearly, by eliminating the restrictions of space, and the appropriateness (or otherwise) of the call-handling centre, it allows for much greater flexibility. In particular, it enables call handlers to work from home, reducing the carbon footprint and overcoming problems of travel, unsocial shift patterns and lone working, whilst giving employment possibilities to those who are unable to leave home due to child minding or caring responsibilities. It also allows physically disabled people who can't use transport easily to enter the work-force and to provide a service that allows them to empathise more with service users.

Such options are not trivial in implementation as they require, firstly, a sophisticated (i.e. new) call handling system which is designed for this purpose. It also requires appropriate telephony and computer equipment to be provided at each call-handler's home, paying appropriate attention to data security and response recovery processes in the event of communications or electricity supply failure. There are also human factor and resource issues to address including the provision of training, supervision and support. Home workers may spend many hours waiting for incidents which don't occur; the ability to remain focused and alert will be important as will be the monitoring of the situation to ensure that performance isn't compromised. It may be difficult to guarantee as would be the policing of confidentiality in and of home environment.

A virtual centre approach might also solve many of the political problems associated with finding the right location for a centre to serve a number of local authority areas. A virtual centre could use staff located anywhere across the region, thus enabling all areas to share in

the employment benefits. It is therefore an option worth considering, even by those partnerships that already have a physical presence at one centre location.

6.6 Summary

A simple comparison of three types of alarm handling centre shows that the most advantageous model is dependent on the local authority or partnership arrangement being considered:

- Small single authorities – the regional model would offer significant financial benefits while offering opportunities of extending the range of provision and the scope of the service to a wider group of citizens
- Regional partnerships – after undergoing the changes required to establish a regional alarm handling centres, there are few benefits to be achieved by changing the model
- Big cities – there may be some advantages in outsourcing provision to a national alarm handling centre, especially if the existing service is struggling to create a monitoring vision for the 21st Century. However, there may be little financial incentive to change the status quo.

Thus, it would appear that it is only small single authorities that need to consider seriously the opportunity of developing new telecare services and opportunities through wider partnership involving other local authorities and agencies in their region. These same authorities could also consider growing services within a corporate call centre environment where the alarm handling centre because integral to the local authority's contact centre for all services.

7. Conclusions & Recommendations

Telecare alarm handling centres in Scotland need to adapt quickly to changes in technology and in the applications that may become available. It is likely that the number of people requiring only a basic community alarm service may decline over the next few years as more people with increasingly complex needs require more advanced telecare applications. These may present opportunities for added value and income, but these will only be possible with investment in equipment, additional staffing, training and IT expertise.

The smallest centres may struggle to justify this investment, and may need to restrict the range of services offered to their partnerships. As services are offered to increasing numbers of people whose risks are defined as critical or substantial, the need for improved performance and reliability may be evident. Further investment must then be necessary to ensure that the quality of service delivery is suitably high. The result is that the size of the centre operations must increase and this may present further problems in recruitment and in accommodating the enlarged service.

It follows that most of the smaller centres will struggle to survive in their present form. There are strong arguments for them to combine with their neighbouring authorities to produce regional call handling facilities where investment is shared, and where economies of scale will permit the required investments in equipment, personnel and training. Alternatively, they may choose to focus their resources on delivering local elements of telecare services such as assessment, installation and response, whilst outsourcing call handling to a national centre.

In order to facilitate more general on-going improvements in services, we offer some suggestions for moving forward in a progressive manner. These are collected under 4 general categories:

- Financial viability;
- Improving performance;
- Local partnership vision; and
- Business plans

7.1 Financial Viability

Alarm handling centres do not always have to be considered as commercial entities; some local authorities see a joint role of the centres in supporting council functions, such as the reporting of housing repairs out of hours, and preventing the escalation of social work issues, as being well worth the investment. Despite the lack of formal evaluation, there are few voices that suggest that the centres, and the community alarm schemes more generally, do not represent good value for money.

However, it is also now recognised that the cost per service user of these centres varies significantly between different areas of Scotland, as does the policy on access to service and on charging individuals to receive a service. Furthermore, there might also be a growing gap in the quality of service offered by the different centres (if this is measured by the scope of telecare applications available. It is unclear whether this is because of local factors, such as the motivation of staff, the number of service users, or the strength of leadership, or whether it is simply related to the level of investment needed to reach an acceptable standard of service delivery. It might also be due to a lack of national regulation and an approach based on standards.

The Joint Improvement Team has collected useful data on the revenue streams that are received by the partnerships operating community alarm and telecare services in Scotland; they do not clearly indicate the level of operating profit or loss for each centre, nor do they show how they would provide capital investment to upgrade the centre equipment rather than the equipment to be installed in the homes of service users. Indeed, it has been historically extremely difficult to compare financial viability of community alarm centres and services because of the lack of a common framework for reporting the details of income and expenditure. The lack of transparency may limit their credibility and the potential for universal support within partnership and, especially, from elected members. This situation needs to be improved.

Recommendation 1:

Develop costs template for consistent reporting across all partnerships.

Recommendation 2:

Collect results of internal cost reviews from all centres.

7.2 Improving Performance

The quality of service provided by alarm handling centres will ultimately determine their success in achieving the outcome ambitions for telecare services as described in Table 7. Few of these are likely to be intimately related to crude call-handling statistics such as the percentage of calls answered within 30 seconds. There is therefore a need to consider more innovatively the measures of performance that genuinely indicate the required outcomes so that appropriate targets can be set, and used for individual centres.

The revised Codes of Practice of the Telecare Service Association (TSA) are likely to go some way towards achieving a softer approach to performance management. However, any changes that are proposed will only be accepted by members if they are not seen as an obstacle to achieving compliance. In particular, member organisations that have already achieved accreditation may see any “moving of the goalposts” as something which undermines their initial investment, and which may compromise their future business case. Thus, the process of reviewing and improving the Codes of Practice will inevitably be slow, and subject to approval by the rank and file membership. Inevitably, there might also be a need for compromise with the result that the changes might come into effect when they again need to be reviewed because of the fast-changing nature of the technologies that underpin applications and service developments. In the short term, the current review of the TSA Codes of Practice may be compromised by an absence of quality standards rather than by any compromises on how difficult individual standards may be to achieve.

New and developing telecare applications will require investment in both equipment and software and in training at all levels. In particular, the ability of call-handling staff to deal with the widest possible range of calls may be evident from the scope of these applications. Deficiencies in current training courses and opportunities are evident.

Whilst accreditation to Part 1 of the TSA Code of Practice may be a worthwhile and desirable starting point, it should not become a factor which induces complacency. In order for Scottish alarm handling centres to be “fit for the future”, further actions may be needed both to establish what is meant by “best practice” and to support individual centres in their ambition to perform at the highest level.

Recommendation 3:

Establish a Scottish performance management system for alarm handling centres.

Recommendation 4:

Investigate the potential of establishing a training board to oversee development of accredited courses and modules.

7.3 Local Partnership Vision

Within a few years, sensor, communication and information technologies will have improved so much that the number and scope of telecare applications may be limited only by the imagination and confidence of the local partnership. Examples of radical change in the delivery

of healthcare services have been driven at a local level by an individual, or group of individuals, who have embraced an emerging model of care which they feel could be applied to benefit their local community. To succeed with this level of change management, local partnerships need to have the confidence to consider a range of novel and innovative solutions without restriction and to share these with across the health and social care sector in order to identify those partners who share this vision.

Elected members, and other non-specialists, often feel sidelined when new initiatives appear, as they don't usually have the background knowledge and experience to appreciate the benefits nor may they be aware of the obstacles that lie in the way of implementation, and the cost of overcoming these obstacles. When they are fully informed then they are generally more likely to be able to appreciate the cost-benefit analysis, and are certainly best placed to understand issues associated with changes in charging policy. Thus, their opinions are likely to influence the general public, and therefore help "sell" changes to the population at large. This may be especially important when outcomes might involve, for example, the closure of a local facility such as a residential care home, a day care centre or a sheltered housing scheme. The support of elected members is essential when charging policies are reviewed because they will understand both the financial pressures on the local authority and the affordability issues experienced by individual service users, many of whom may be on fixed incomes.

Recommendation 5:

Encourage local partnerships to produce a strategic vision identifying the scope of telecare applications.

Recommendation 6:

Local partnerships seek to identify local champions to promote telecare strategies within councils, health boards and across the wider community.

Recommendation 7:

Information packs are prepared to explain the features and benefits to elected members who may have limited professional knowledge of the health and care sector.

7.4 Business Plans

As new partnerships evolve, especially those involving several local authorities across a region, both the start-up costs and the on-going revenues will be of great concern to all. One of the

greatest pressures on a new structure is financial viability; if the business unit becomes loss-making, then its future immediately is cast into doubt. Telecare services and the individual service elements, including call-handling, must therefore be considered in a business-like manner, with robust projections for costs and income over a significant period of time, and a sensitivity analysis which identifies risks to future income, and the potential for business growth.

The income potential of alarm receiving centres is easily underestimated. In particular, the need to satisfy healthcare concerns of "the worried well" is often neglected in order to concentrate on people who have profound needs. However, the unit cost of service delivery for many telecare services depends intimately on the level of provision, which means that recruiting more private payers will reduce the costs for other service users. It also means that more service users can have applications for the same cost to the alarm centre. The benefits accruing to all members of the partnership need to be considered against the financial contributions made by that business partner to the operation of the partnership.

In the same way, different methods of operating may be introduced which influence the overall cost and effectiveness of service delivery. Thus, the links between business costs and business aims need to be considered and measured in an on-going manner. Monitoring of business activity is a managerial function that is needed on a continuous basis, and methods put in place to ensure that reviews are made available regularly and shared with the partnership board.

Recommendation 8:

Actively seek buy-in from health boards and trusts, RSLs and councils.

Recommendation 9:

Prepare marketing and promotional plan for services.

Recommendation 10:

Local partnerships put in place a robust management structure to ensure that business plans are reviewed and updated on an annual basis, and actions taken as appropriate to achieve success.

Recommendation 11:

Business plans follow a standard format and should include targets for the next 5 years.

Recommendation 12:

Local partnerships undertake annual reviews and external evaluations of services using a standard framework.

Recommendation 13:

Local partnerships ensure that the services that are offered to private individuals are properly costed so that they offer good value for money for both the individuals and for the health and social care economies.

8. Appendices

8.1 Section 2 - Introduction

8.1.1 Telecare Call-Handling Arrangements across Scotland.

Call Handling Service Provider		Clients	Equipment
1	Aberdeen Regional Communications Centre (ARCC)	<i>Aberdeen City, Aberdeenshire, Highland Moray</i>	Tunstall PNC-4
2	Dumfries & Galloway Care Call LA Community Alarm Service	<i>Dumfries & Galloway</i>	Tunstall PNC-4
3	Dundee City Community Alarm Service	<i>Dundee City</i>	Tunstall PNC-4
4	East Lothian Community Alarm service(ELCAS)	<i>East Lothian</i>	Tunstall PNC-4
5	Glasgow City Council Community Alarm Service	<i>Glasgow City</i>	Tunstall PNC-4
6	Midlothian Council	<i>Midlothian</i>	Tunstall PNC-4
7	South Ayrshire Monitoring Service	<i>South Ayrshire, North Ayrshire</i>	Tunstall PNC-4
8	Scottish Borders Council - Bordercare Community Alarm	<i>Scottish Borders</i>	Tunstall PNC-4
9	Shetland	<i>Shetland</i>	Tunstall PNC-4
10	West Lothian Careline	<i>West Lothian</i>	Tunstall PNC-4
11	Hanover Telecare	<i>Argyll and Bute, Renfrewshire</i>	Tunstall PNC-4/5
12	East Dunbartonshire Council - Hourcare 24	<i>East Dunbartonshire, West Dunbartonshire</i>	Tunstall PNC-3
13	North Lanarkshire Council	<i>North Lanarkshire</i>	Tunstall PNC-3
14	South Lanarkshire Council Housing & Technical Resources	<i>South Lanarkshire</i>	Tunstall PNC-3
15	Stirling Council - Contact Centre	<i>Stirling, Clackmannanshire</i>	Tunstall PNC-3
16	Faire Community Careline Service - Social Work Dept	<i>Eilean Siar (Western Isles)</i>	Tunstall PNC-3
17	Angus Council Community Alarm Scheme	<i>Angus, Backup with Perth & Kinross</i>	Chubb (formerly Initial / Attendo)
18	Falkirk Council	<i>Falkirk</i>	Chubb
19	Fife Council Community Alarm In House	<i>Fife</i>	Chubb
20	Perth and Kinross Council	<i>Perth and Kinross, Backup with Angus</i>	Chubb
21	East Ayrshire Control centre	<i>East Ayrshire</i>	Jontek

Call Handling Service Provider			Clients	Equipment
22	Edinburgh CEC Community Alarm Service		Edinburgh	Jontek
23	Bield Response 24		East Renfrewshire, Inverclyde	Jontek
24	NHS Balfour Hospital		Orkney Islands	Unknown

8.1.2 Anticipated Changes in the Composition of Households in Scotland

The proportion of people living alone in Scotland is expected to increase from 34% of all households to 42% within a period of 20 years. This will also add to the demand for telecare and related services. The ageing population is also reducing the capacity of care services (formal or informal) across the UK, which is already struggling to meet the demands placed upon it – a situation which is likely to get worse. Indeed, the dependency ratio (defined as the number of people of working age to those who are retired) is likely to fall from 4:1 to only 2.5:1 in much of the developed world within the next 40 years. It may be apparent that these factors will contribute to a situation where there will be increasing numbers of people competing for the services of a decreasing number of carers.

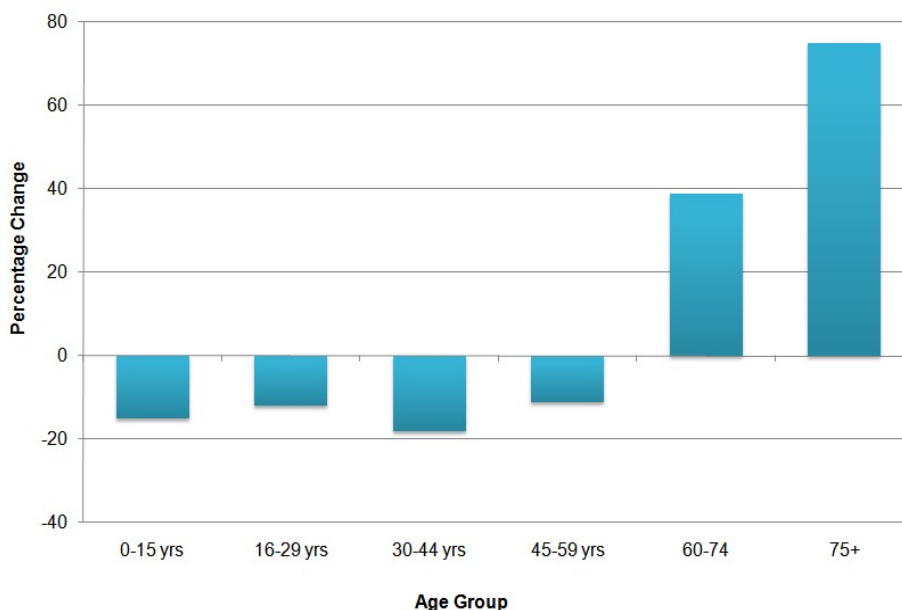

Figure 14. Projected Increase in Scottish Population 2004-2031 by Age Group.

Figure 14 shows the projections for individual age bands, from which it may be observed that the biggest increase (75%) occurs in those people aged over 75 years. These have been the traditional users of community alarm systems, and are also the target for most telecare services. The implication is that the potential growth of services to meet these demands will be substantial for the next quarter of a century. In 2005, Scotland had almost 1,200 sheltered housing schemes offering 36,000 dwellings with a further 145 Extra Care (or housing with care) schemes with just over 3,700 dwellings.

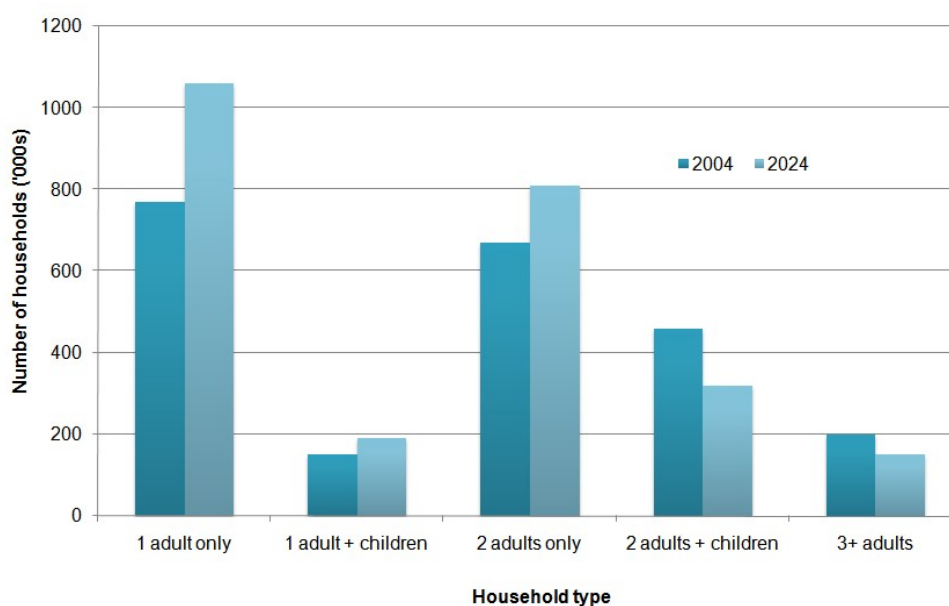

Figure 15. Projected Changes in Scottish Household Types: 2004-2024.

Table 3 shows that the reduction in the number of units of sheltered housing has been dominated by a 11% reduction in schemes operated by Registered Social Landlords (as a percentage of the entire stock) between 2003/4 and 2005/6 ^[28]. This is in part due to a remodelling of sheltered schemes into either Extra Care or general needs provision – though some of the schemes which are most difficult to let may have been demolished ready for site redevelopment.

Table 13. Changing Make-Up of Sheltered Housing Between 2003 and 2006.

Sector	2003/04	2004/05	2005/06
RSL	27%	26%	16%
Local authority	53% Social Work 25% Housing 28%	53% Social Work 25% Housing 28%	59% Social Work 38% Housing 21%
Private companies & individuals	17%	17%	20%
Other	4%	2%	3%
Voluntary orgs	0%	2%	2%

Due to the high cost of remodelling, and the growth in home ownership of older people, the rate of sheltered housing provision may fall from a rate of 38 per 1,000 people aged over 65 in 2005 to a rate of between 25 to 30 units per 1,000 older people over the next 10 years. This represents a decrease of some 10,000 alarm connections across Scotland, mainly in those areas where there are higher percentages of older people using the system.

8.2 Section 3 – Technology Drivers

8.2.1 Future Connectivity & Sensor Platforms in the Home

Pressure from service users, providers and commissioners for plug and play interoperability between all telehealthcare devices will mean that future systems will need to have improved connectivity options. Connectivity technologies for wireless networks are focussing on increasingly smaller areas – moving from Local Area Networks which might cover an entire building to Personal Area Networks (PAN) which cover a few metres and finally on to Body Area Networks (BAN) which cover an individual person. There are a number of established and emerging wireless-based technologies of relevance to telecare:

- **Bluetooth** – a relatively low-cost and low-power wireless technology with typical data rates of ~1Mbps that is primarily designed for short-range^{ix} voice and data communications. It is often considered to be a cable-replacement technology as it allows for relatively large amounts of data to be transferred. Example applications are to link physiological sensors to a telehealth monitoring unit and the distribution of bi-directional audio throughout the home to remove the current problem when a care phone is in a different room to a service user in distress;
- **Zigbee** – a low-cost and low-power radio networking technology with data rates of up to 250 Kbps with transmission distances ranging from 10 to 100 metres. It is designed for low-power sensor/control applications (e.g. remote control, home automation) where small amounts of data are required to be transmitted (e.g. event-based data and commands); and
- **RFID** – a near-field communications technology that uses un-powered (passive) or powered (active) tags in conjunction with a reader device to transfer small amounts of information over a short distance (a few centimetres for passive tags up to a couple of metres for active tags). These tags may initially be used as an omni-directional replacement for bar-codes (e.g. on food packages) but could also be used to tag everyday household items (e.g. for lifestyle monitoring applications) or used to convey information in conjunction with external inputs or sensors.

The Toumaz Technology Sensium™ is an ultra low power sensor interface and transceiver platform for a wide range of applications in healthcare^[29]. The device includes a reconfigurable sensor interface, associated processing and microcontroller with on-board radio. On-board processing capabilities can help produce smart sensors that can transmit data on a need to know basis. The Sensium system can interface with a number of sensor types including: ECG, temperature, blood glucose and oxygen levels and can also interface to tri-axis accelerometers, pressure sensors and includes a temperature sensor on-chip.

^{ix} typically 10 metres although up to 100 metres is technically possible.

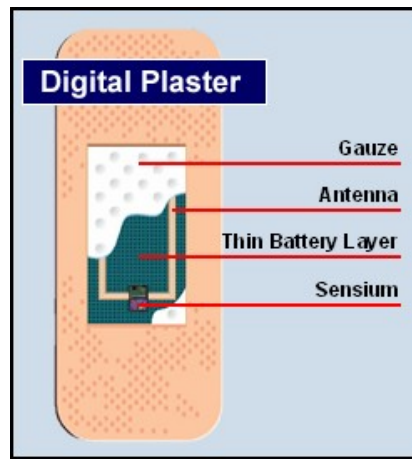

Figure 16. The digital plaster 'smart sensor' concept.

They propose the 'digital plaster' concept incorporating the Sensium platform that can be used to continuously monitor various physiological parameters and report to a base-station. Another technology is the Vena platform^[30] which embeds both the emerging IEEE 11073 standard and the emerging Bluetooth Medical Device Profile, optimised for the secure transport of medical data, onto the single chip, Figure 17.

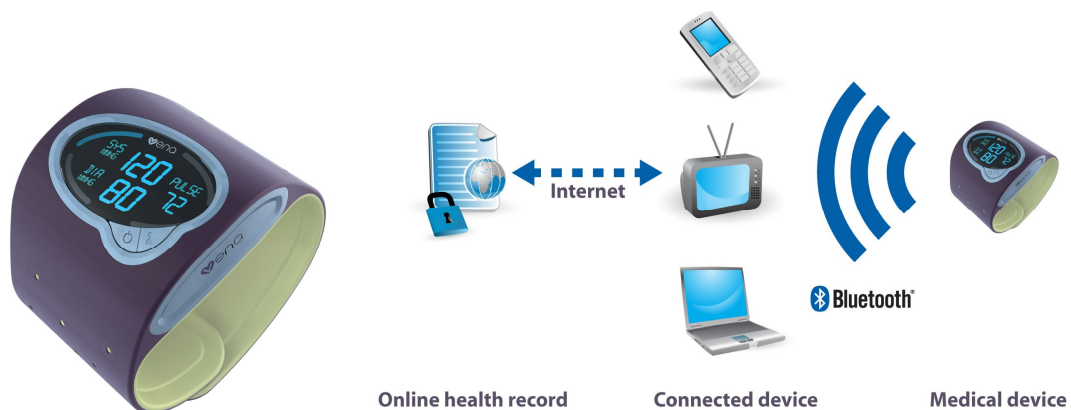

Figure 17. The Vena platform for wireless medical device monitoring.

It has undergone proof of concept testing using a pulse oximeter and weighing scales and is to be extended to include other types of devices including blood pressure monitors. Devices using this platform may become commercially available by the end of 2008. The platform also supports Wi-Fi or Ethernet connections or can even be used to transmit data via mobile phones.

8.2.2 The Home Hub of the Future

As separate operating platforms converge (i.e. alarm-based telecare, lifestyle monitoring and telehealth), the home hub is likely to evolve into a more advanced 'set-top box' which will be responsible for implementing 'local intelligence' as well as potentially providing telecommunications into and out of the home, Figure 18.

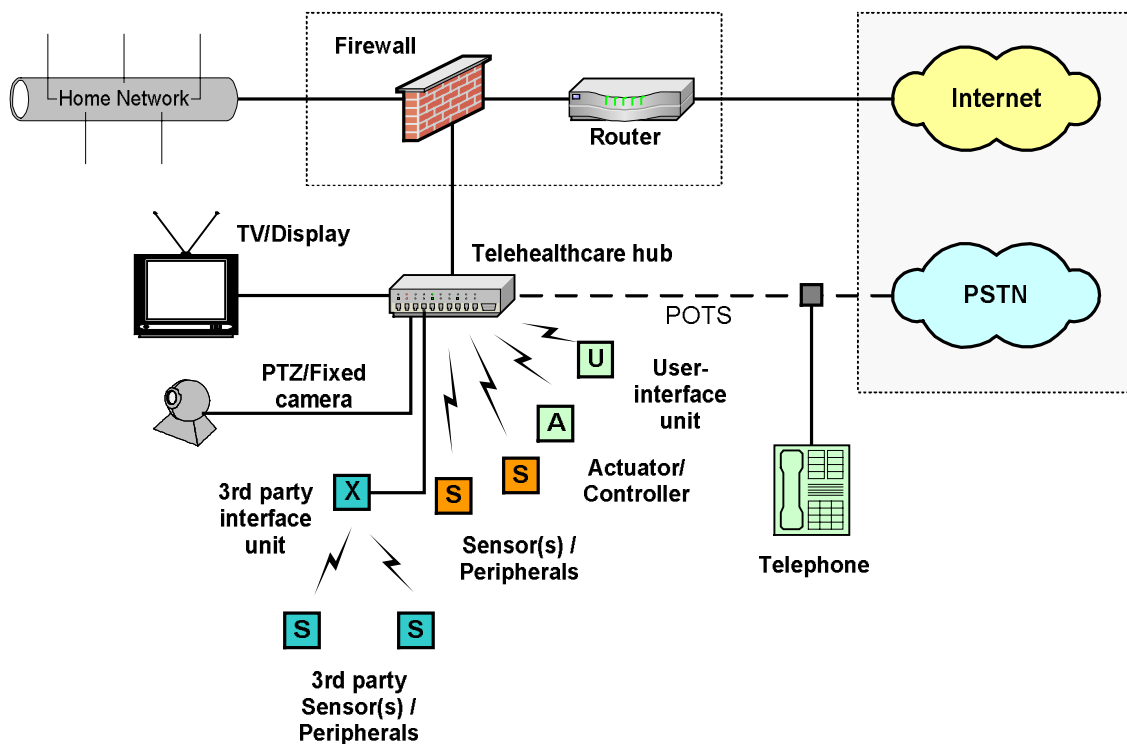

Figure 18. An integrated home healthcare environment.

Alarm information is currently transmitted from the care phone in the home to the monitoring centre over the telephone network (PSTN) using DTMF ('touch tone') voice-band signalling, which is exceptionally slow compared with modern standards. Newer care phones and lifestyle & telehealth monitoring units have an integral 'dial-up' modem, capable of transmitting data at higher speeds. Next-generation care phones are likely to be IP-based, incorporating broadband (ADSL) modems, providing an always-on connection with much faster data transfer speeds again^x. In some circumstances, where a landline is not available (for example if the bill has not been paid) it may be possible to use another telecommunications network such as the mobile phone network (GSM).

The user-interface aspect of the home-hub is likely to evolve as 3rd generation applications become available that enable personalised video content to be delivered to the service user (e.g. to help them self care and become expert patients). In the future, the user interface to a home-based telecare or smart home system may become distributed throughout the home and integrated into everyday items such as a television, bathroom mirror or fridge or even items of clothing, Figure 19.

^x The actual speed depends on the ISP package as well as the quality of the landline and the distance from the exchange.



Figure 19. Future user interface technologies for the home with ambient intelligence.

The vision then for the next 5 to 10 years is a combined telecare and telehealth monitoring unit which offers more wireless connectivity options, is more adaptable and intelligent and can perform some level of home automation. It will have its own IP-address and operate over a high bandwidth broadband connection. It will either plug into a broadband-enabled set-top box which will be responsible for telecommunications into and out of the home; or the entire functionality may be integrated completely into a specialist set-top box for home healthcare applications.

Some systems of this type are already beginning to appear on the market e.g. the Mediagrids CareHub, although their efficacy has yet to be proven. They might also include features such as PZT (pan-zoom-tilt) cameras which many potential users would view as part of a surveillance system rather than a means of providing video interaction.

8.3 Section 4 – Call-Handling Services

8.3.1 Mobile Phones for Older People

There are a large number of mobile phones appearing either in Japan, the USA or Europe that are designed specifically for older people with respect to ease of operation. The Jitterbug from the USA has specific buttons for the operator and for emergency services, but the inclusion of a button for towing services implies that its primary audience may be car drivers rather than older people (left-hand image, Figure 20).



Figure 20. User-friendly mobile phones from outside Europe.



Figure 21. European Mobile Phones for Older People.

A number of similar mobile units are already available in Europe, many of them marketed through charities for older people or for people with visual or hearing problems. Emporia Life (left-hand image, Figure 21) is a simple to use, black palm sized mobile phone, which allows you to make and receive phone calls and send and receive text messages. It has a number of features designed specifically with older people in mind, including:

- the text size on the buttons is 24 point. The text size on the menus and other main functions is in 20 point. The text size on screen when writing or reading a text message is 16 point. The text size when you dial a number straight into the phone (not via the contact list) is 36 point;
- it has a large orange back-lit display, with enlarged black text;
- it has an easy to locate "emergency" button on the back of the phone that can dial personalised pre-set contact numbers.

The EasyUse (centre image, Figure 21) is lightweight (114g) and has a highly visible large blue button keypad. Its slim design means that its easy to operate by people with dexterity problems. The screen is transfective, which means that the black and white display is very clear, even in direct sunlight and is perfect for people who have a visual impairment. The 'Easy 5' (right-hand image, Figure 21) has 5 large buttons each of which can store 1 contact number as a speed dial. These can be pre-programmed on purchase. The Italian designed 'Easy 5' has been specifically modelled to allow users to grip the handset effortlessly and locate its buttons with ease.

Finally, there is the Burnside P23 desktop mobile phone which combines the simplicity of a desktop phone with the flexibility of a mobile phone.



Figure 22. The Burnside P23 desktop mobile phone.

This unit is designed for:

- People who have difficulty using a handheld mobile phone;
- Those who live in an area with a weak mobile signal;
- Anyone who is located in any temporary location or where landline telephones cannot and will not be provided;
- Individuals who use landline phones to make lots of calls to mobiles and who wish to make much cheaper calls.

8.3.2 New Sensor Systems

Existing systems for the detection of nocturnal enuresis rely on sensors that are installed between the mattress and the top-sheet. This means that by the time the alarm has been triggered, the client has been wet for some time with implications for comfort and pressure sores. It also means that the client has to be disturbed in order to change the bedclothes. The Dri Sleeper Eclipse is a new device which has been designed to solve the problem of bedwetting in children, Figure 23.



Figure 23. Dri-Sleeper wireless enuresis sensor.

It consists of a re-chargeable small urine sensor that can be placed in an incontinence pad worn by the person being monitored; it can raise an alarm *wirelessly* to a base unit, which is designed to wake up the child immediately when they urinate and before they wet the bed. It thus avoids the need to change bedding and bed-clothes and promotes a change in behaviour pattern. The sensor is non-metallic and therefore there is no corrosion by urine, no skin irritation, and it is easy to clean for instant reuse. This has clear applications in telecare to improve the management of nocturnal enuresis in the community.

In addition to product improvements, new applications are likely to become available including medical alarm telecare - a first generation telecare application involving the remote detection of emergency situations through sensors worn on the body. These might include cardiac arrhythmia detectors, devices to detect hypoglycaemic incidents, and systems that detect a blockage or an accidental removal of a catheter. Hence, they are ideally suited to application through the telecare alarm infrastructure where a rapid response can be organised. Some are already available but not yet configured for use with a telecare system.

8.3.3 Health Coaching in Birmingham

The Birmingham Ownhealth project originally involved a focus on three disease areas – diabetes, Heart Failure and Congestive Heart Disease – but has since been extended to include chronic obstructive pulmonary disease (COPD). 1108 patients were enrolled over 13 months of whom 844 were still active on the programme at the end of the 12 month project period^[31].

Figures 24 and Figure 25 respectively show how the service has engaged considerably more people in attempts to increase their levels of physical activity, to improve the diets and to stop smoking.

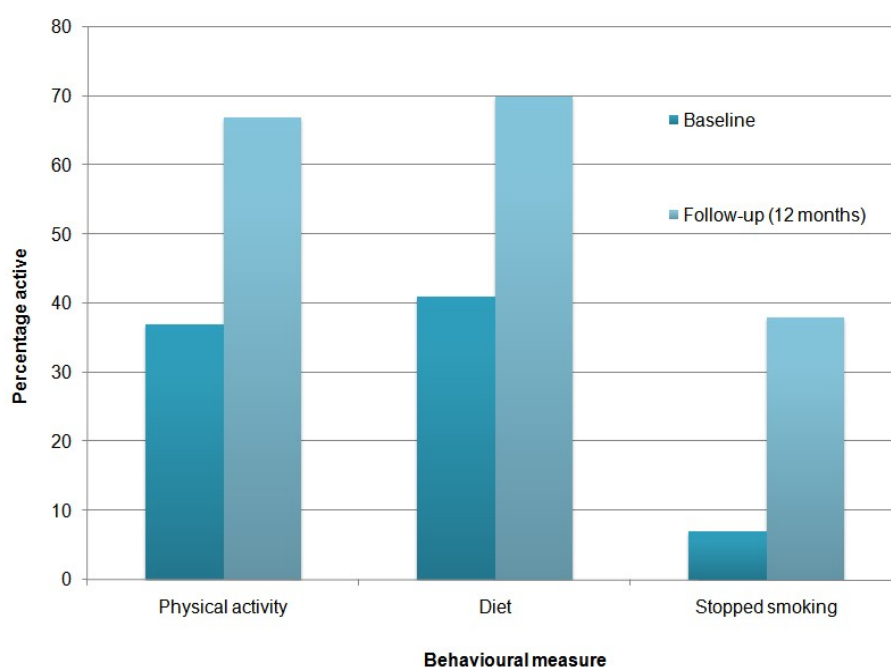

Figure 24. Behavioural changes due to project.

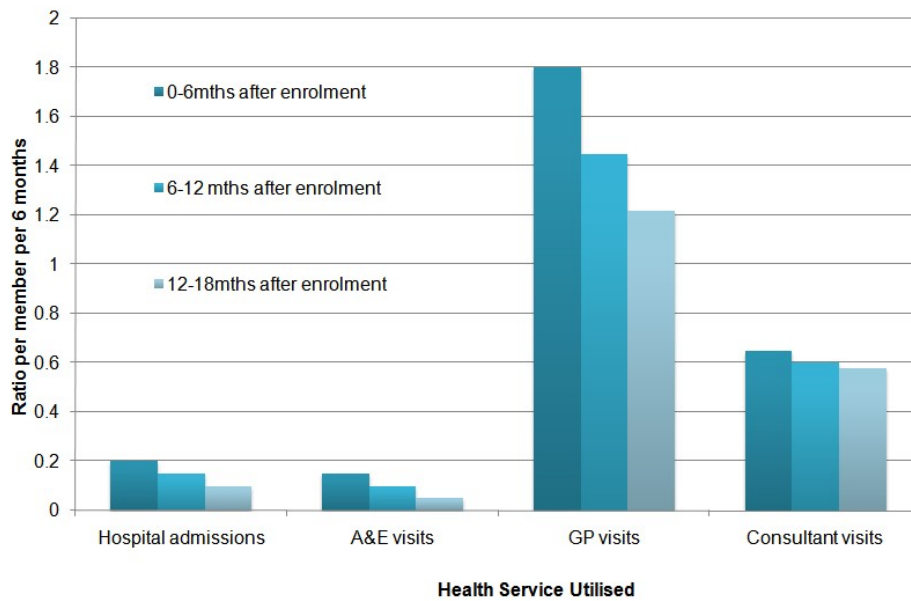

Figure 25. Changes in the use of services.

The impact has been to reduce all four types of service available through the NHS with an average cost per annum to the NHS of £950 at the start of the project reducing to £540 after 12 months i.e. £410 savings per participant. The greatest percentage reduction in service was in visits to A&E i.e. unscheduled care, which is consistent with the aims of telecare services. This was reduced by 53% over 18 months reducing the average cost per participant per annum from £26 to £12.

8.3.4 Key-safes and Electronic Access Methods

There are various models of key-safe on the market. The 10 digit push-button varieties offer about 1000 different code combinations while the 12 digit versions have over 4000 different combinations available. Versions with 4 wheels offer 10,000 different combinations (Figure 26).



Figure 26. Example key-safes.

In each case, the weakness of the solution is due to its management rather than the mechanical integrity of the device. Unless access codes are limited to genuine emergency

situations then there is a likelihood that a regular user may forget to return the key to the safe after use, so that the safe is empty when used in an emergency. Codes need to be generated randomly and the data maintained in a safe and secure manner at all times. Electronic door locks allow the service user to remotely open a lock using a remote control device and are used in conjunction with a door intercom system (Figure 27).

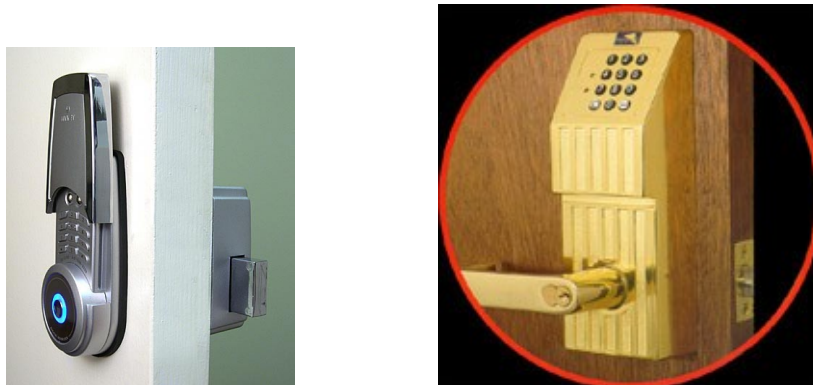

Figure 27. Example electronic door locks.

The lock can also be operated by a monitoring centre using the care phone as the interface. This allows the call handling staff to confirm the identity of the visitor before admitting them. This method will soon be extended through the use of IP-based cameras and ADSL communications to link with a door camera to allow the monitoring centre to capture the image of the visitor. This assists the process of verifying the identity of the caller and also provides an audit trail for subsequent review. Digital door locks are becoming popular for both internal and external doors. Issues of code management are similar to those for key-safes, but the increased costs associated with their purchase, installation and management make them attractive to only some groups.

8.3.5 Tracking Technologies

An example of a mobile phone device that is suited to person tracking is the Mio A701 as shown in Figure 28.



Figure 28. A GPS enabled mobile telephone – the Mio A701.

When operated with special software, this enables the device to be tracked in real-time (rather than being located at a moment in time). The advantages are that it offers:

- help to locate someone even if they are out of mobile signal range;
- geo-fence alerts if they have moved outside a safe area;
- lack of movement alerts if their position has remained the same for a lengthy period;
- a breadcrumb trail for up to a month showing where they've been; and
- the ability to easily to monitor multiple people at once.

However, it should be noted that geo-fencing applications with mobile phones can be a problem when used at home as the lack of a GPS signal indoors can lead to false alerts. There are a number of different services already operating in the UK though the success of their applications often depends on the location and the number of phone masts in the area. Organisations that offer this service include:

- Mapamobile.com
- traceAmobile.com
- Childlocate.co.uk
- eptier.com
- Followus.co.uk
- Trisent.com
- Mobilelocate.co.uk
- Bluetreeservices.co.uk; and
- Urfreesim.co.uk
- findyourchild.net

Of course, as the devices are actually mobile phones, then they also allow the monitoring centre (or a carer) to telephone the user in the hope that they can have a conversation which helps them to come back without becoming anxious.

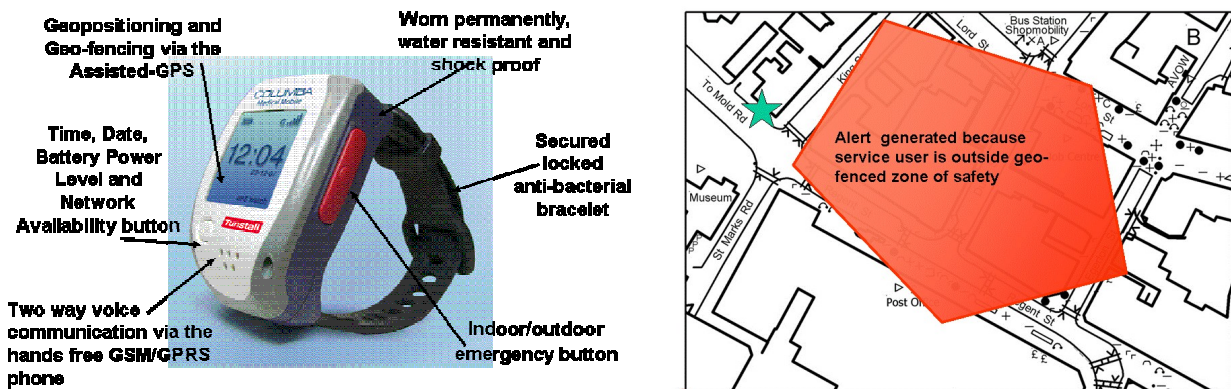

Figure 29. Columbia GPS bracelet and its use with geo-fencing alerts.

The latest innovation combines a mobile phone with a watch and GPS location and geo-fencing in a device that can be worn on the wrist as shown in Figure 29. This is soon to launch in the UK and has already attracted significant interest following a successful pilot and a redesign based on improved usability. Similar services are now operating in North America and in Europe. Figure 29 also shows the geo-fencing in action. In this case, the geo-fencing only switches on when the "watch" goes out of range of the home base unit.

Simpler solutions based on tags that were originally designed for locating lost pets may also be used in a similar manner with people when they forget/don't like to carry a mobile phone or to wear a watch. In some cases, and where ethical issues have been resolved, it is possible to place a tag (such as the one shown in Figure 30) inside a favourite jacket, a handbag or a wallet. Attachment to a key-ring is a popular option with service users.



Figure 30. The Buddy GPS tag system.

It allows tracking over the internet to locate that person at any time, using either GPS for a high resolution location (as in Figure 31) or as the most recent GPRS fix using mobile phone masts.



Figure 31. Location finding with the Buddi GPS.

Under certain circumstances they may be sewn into items of clothing or worn on a belt as shown. Such devices lack the ability to provide direct communication with the wearer, and also are not suitable for geo-fencing applications because of satellite visibility issues. However, an upgraded version will shortly be available with an extended battery capabilities and geo-fence alarm options. The above devices (Buddi GPS and Columba bracelet) are suitable for operation through a monitoring centre. Two other devices, shown in Figure 32, are for more personal tracking use by families. They may be seen as competitive to the model that using an alarm handling facility.



Figure 32. Two New Hand-held GPS Tracking Devices.

8.3.6 Amego & Alert Me Systems

The Amego system uses individual pendant (see Figure 33) worn by service users and linked into a risk management system to allow alerts to be generated according to the location of that person. Location is identified by the nearest transceiver, which can alert the nearest member of staff by pager.

Service User	Mobility Analysis	Alert History	Assessment	Notes	Risk Summary
Alert Profiles and Mobility Settings	Location risks	Location Group Risks	Location Time Limits	Social Risk	Required Locations
This page allows you to specify which single locations are potentially hazardous for this service user					
Room	Location	Risk Presence	Risk	No Risk	
1st Floor Hall	Fire Exit	●	Risk	No Risk	
1st Floor Hall	Top of Stairs	●	Risk	No Risk	
1st Floor Hall	WC	●	Risk	No Risk	
1st Floor Rear Hall	By Rm 13	●	Risk	No Risk	
Conservatory	Dining Rm-Left	●	Risk	No Risk	
Conservatory	Dining Rm-Right	●	Risk	No Risk	
Front Garden	By The Chickens	●	Risk	No Risk	
Front Garden	Corner Patio	●	Risk	No Risk	
Front Garden	Sun Deck	●	Risk	No Risk	
Front wall	Bottom of Stairs	●	Risk	No Risk	
Front wall	By Front Door	●	Risk	No Risk	
Front wall	By Rm 4 & 5	●	Risk	No Risk	
Front wall	WC	●	Risk	No Risk	
Kitchen	In The Kitchen	●	Risk	No Risk	
Kitchen Hall	By Rm 13	●	Risk	No Risk	
Kitchen Hall	WC	●	Risk	No Risk	
Lobby	In BathRm	●	Risk	No Risk	
Lounge	By Cinema Area	●	Risk	No Risk	

Figure 33. The My Amego risk management system being set up.

Figure 34 shows the smart home arrangement of the AlertMe system, based on a broadband connection and dispersed sensors.

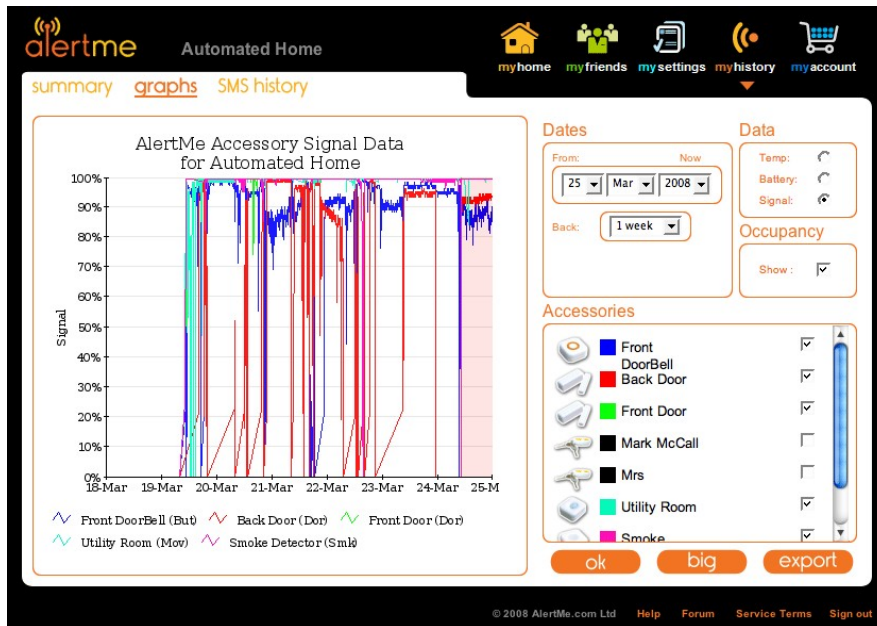

Figure 34. The Alert Me System of Sensors and Alarms Using a Home Network.

8.3.7 Lone Worker Systems

Telephony-based systems that require the worker to log in using a mobile (or landline) phone leaving their name, contact details, duration of visit and time they will finish using the keypad or using Interactive Voice Response (IVR) based systems. The worker can also append a voice message. The user can then log in to the system to extend this period or to cancel the event if they have finished.

- Check calls can be initiated periodically to request that the worker confirm that they are alright;
- Mobile phones with integral panic buttons that enable the worker to raise an alarm. Some also incorporate a GPS module so that the monitoring centre can locate them with integral mapping software;
- Body-worn sensors to monitor 'man-down' or lack of activity – essentially mobile alarms that dial in if the worker has fallen or is not active for a particular length of time;
- Standard telecare devices/alarms that can be used for workers in fixed environments and who are low risk.

If a user does not extend or cancel the message by the designated time or if an alarm is raised, an alert is instantly raised with a 24-hour Monitoring Centre, where the user's details are displayed and their last message is played. Appropriate action can then be taken which involves attempting to contact the worker, followed by named contacts until a valid acknowledgement is received.

8.3.8 Lifestyle Monitoring

Four major applications for lifestyle monitoring are emerging which are likely to lead to growth in services and additional monitoring centre needs. They are described below along with the potential role of alarm handling staff in each of these areas.

8.3.8.1 Assessment of Needs and Risks

It is generally recognised that an assessment using the Single Shared Assessment (or equivalent constructs in England and Wales) offers a snapshot view which can change rapidly with time and with external circumstances. The opportunities to miss a problem or to detect risky examples of behaviour are considerable because they may be restricted to certain times of day or night, or certain days of the week. They might also depend on the individual's current state of mind, or on the presence or absence of behavioural triggers. It follows that a period of monitoring of a few weeks would increase the opportunity to detect particular types of behaviour or to show that a certain type of problem does not seem to exist.

The above is the basis of promotion for "Just Checking", a simple 2nd Generation Lifestyle monitoring instrument for monitoring movement levels in different rooms of the house during the day and night developed by the company of the same name, based in Warwickshire. The system offers basic information only, as shown in Figure 35 for a 24-hour view and for a shorter, more targeted window in time. It is web-based, and uses the mobile phone network for uploading data on demand. It is therefore completely independent of the telecare hub.



Figure 35. LM movement data over 24 hrs (left) and Detailed view of movement.

This technology is in use in over 40 local authorities in England (> 25% of those with Social Services responsibilities), with interest already from a hand-full in Scotland. It is being considered by some commissioners as an essential assessment tool prior to care home admission for funded cases. Unpublished data from Staffordshire suggest that it can significantly reduce the number of inappropriate admissions whilst delaying admission.

The role of the alarm call handling staff at the monitoring centre is unclear as the technology does not offer any system intelligence to flag up problems. If the centre is involved in the installation and withdrawal of the equipment, then they are probably best placed to prompt the professional staff to look at the data. On the other hand, if evaluations show that the system is only capable of detecting particular types of problem, then the alarm handling staff may become trained to offer a more specialist service in interpreting data, or flagging up areas to be queried.

In the future, it is likely that similar views will be available from other mainstream telecare providers including Tunstall and Tynetec. However, other organisations may attempt to combine specialist sensors with applications aimed at particular groups such as those suffering from dementia. These might include tags that are used for location or for differentiating movement or activity performed by different people. To avoid removal, some devices may be embedded under the skin of service users or in their clothing.

8.3.8.2 Mid or Long-term Trends Analysis

Over an extended period of time (i.e. longer than 4 weeks), it is possible to determine “usual” levels and patterns of certain activity, times in certain areas or visits to particular rooms. This allows particular events to be displayed as a log of the number of events per day for comparison with the norm. These events might include the number of visits to the kitchen or to the bathroom, or the number of times the individual got out of bed during the night. Of course, such events are often assumed rather than definitively identified as, for example, movement detected in the kitchen does not unambiguously mean that food was being prepared or consumed during that visit. Similarly, visits to the bathroom can be associated with the airing of clothes as well as for reasons of hygiene. When more data are available, it allows the derivation of parameters such as a “hygiene index” or a “nutrition index”. These are based on several different inputs thereby eliminating many of the uncertainties associated with movement detection and room occupancy alone. These may be colour-coded for impact or could form the basis of information statements that flag up significant declines in condition, or changes in habit. A typical display is shown in Figure 36.

Such alerts would not be considered as alarms in the sense that they need immediate intervention, but may prove useful in demonstrating the need for review. The indices are not necessarily clinical so it may be appropriate for either red alerts or amber alerts to be flagged to alarm handling staff for intervention purposes. The interventions will depend on the actual problem identified but might range from calling or e-mailing a relevant health or social work professional, informing an informal carer, or speaking with the service user to provide a more immediate form of support. Previously, the significance of colour coded alerts has been relatively unknown because of the lack of evidence. Over time, these scales will no longer be

arbitrary and may be calibrated to yield more specific results, enabling call handlers to respond with more standardised response protocols.

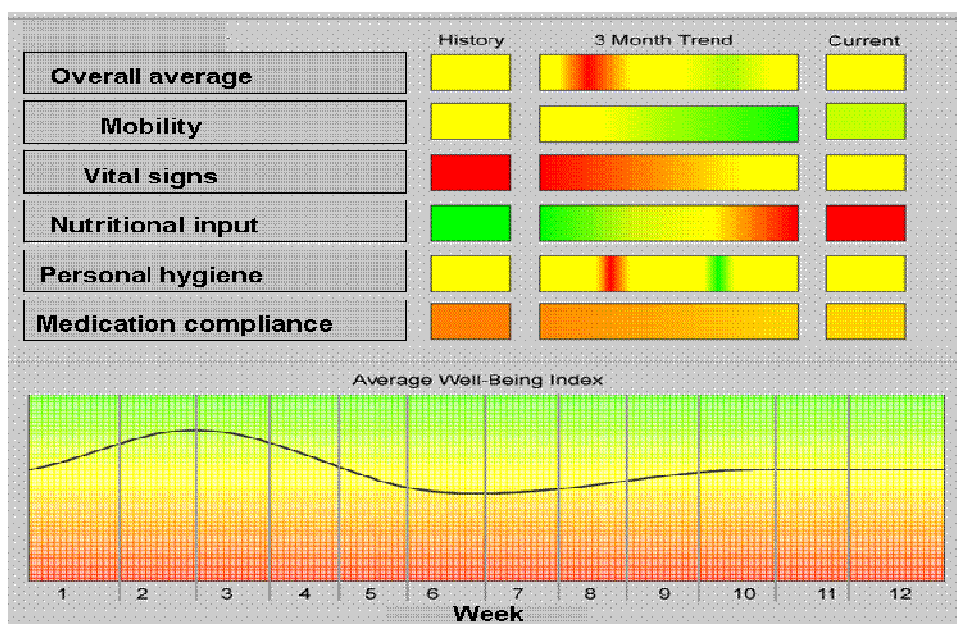

Figure 36. Traffic light display system (based on BT sample interface 2007).

The quality of indices derived from sensor data will depend largely on the number and type of sensor employed within the LM system. Clearly, the data cannot be limited to outputs of movement detectors and door status sensors. Generally, the greater the number and type of sensor employed then the better will be the correlation between derived indices and more robust measures of performance such as the activities of daily living. The final well-being index will be a construction which might also involve alarm history, self-assessment results and contextual factors. Algorithms for the determination of well-being are only now being proposed, but once they are validated, the growth of LM for trend analysis is likely to be significant and limited not only to older people. Groups who have mental health problems and those who have recently received reablement or other therapies may also be monitored in this way. The impact on the monitoring centre could be high because of the demands for data and interpretation at any time of day or night when constant monitoring may be required.

Training and the skills development requirements will depend on both the number of different systems employed in the field, and on the responsibilities that will be placed on alarm centre staff. In the future, there may be integration of systems, with double entry capability, multiple views, and data transferred to a single client record.

8.3.8.3 Pseudo-Real-Time Alarms and Interventions

Currently, alarm conditions are governed by pre-defined rules relating to lack of movement for a given period of time, for example. They are based on algorithms that may average effects over long times, or which allow health and social care professionals to use their clinical judgement to set up the alarm criteria. Generally, such alarms are based on exception

monitoring e.g. if there has been no movement for 4 hours then something may be wrong. Of course, there may be nothing wrong if it happens to be 4am or if the individual has chosen to go out for a walk. In a full LM system, the above examples would not produce an alarm because other sensors or information sources would have detected that it was night, and the person was in bed, or that they had left the property. These additional sensors are likely to be more expensive than the standard sensors used to identify movement, therefore, they will not always be used. There is then a temptation to produce a "best guess" at an emergency based on limited knowledge. This approach, supported by sophisticated computing algorithms can yield many different types of alert many of which may have a significant preventive application. Additional interventions will result in more calls paid for by the service user but an insignificant amount of electricity because the sensor systems are battery powered.

Some systems claim significant benefits when used to detect falls. However, when the number of data inputs is limited, there will inevitably be uncertainty. In other words, there will be significant numbers of false alarms generated by the LM system. When the results for a falls pilot project in one English local authority were analysed by the current authors, they found that only 10% of events that the LM system identified as falls in the bathroom were correct. In the same way, only 4% of alerts based on a general lack of movement needed any intervention. None of those alerts based on a lack of movement in the morning was related to a fall event. It will be impractical for clinical or professional field workers to respond to all these alerts. Therefore, they will depend on the alarm handling staff to filter out the obvious errors so that there are fewer interventions needed by the responders. Better training and improved protocols when combined with good clinical judgement and personal experience will reduce the number of problems identified with these systems.

8.3.8.4 Reminders, Alerts, Information and Advice

In the future, many LM systems will have local intelligence giving them the ability to monitor and then interact with the service user in order to promote independence. Reminders may need to be issued when tasks are not performed at the designated time, and prompts offered when there may be a delay in following through a sequence. The LM system must therefore provide appropriate user interfaces to avoid the possibility of being ignored or of being too complex to be useful. Natural interfaces will include music systems, the TV and additional screens on surfaces such as the refrigerator, bathroom cabinet, bed head and exit door, as well as on mobile devices (including telephone and MP3/4 player). These lead naturally to more general displays of information, advice and counselling, and applications of health coaching and promotion which will become increasingly relevant as technology and services move into a third generation of telecare.

However, an escalation procedure will be required in order to reinforce any automatic reminders or prompts that have been ignored or confused. Similarly, when the service user is

confused they will require feedback and answers to questions. These can be provided only by having a human in the loop to mediate and to ensure that there is an auditable trail of messages, reminders and actions. In the future, similar systems may be used to help avoid obesity by monitoring calorie intake, expenditure and weight over time, and by advising dietary changes and more exercise as appropriate.

8.3.9 Telehealth Application Example

Uploaded vital signs and other telehealth data are processed in order to generate trends and summary reports and highlight potential problems where data lie outside an acceptable range. It is important to stress that existing telehealth systems **do not** generally provide a real-time alarm function; rather, alerts and trends are examined retrospectively and 'off-line' by trained staff. At the monitoring station (a PC with a network/internet connection) an operator uses a either a bespoke stand-alone application or a web-based interface to setup new patients details and alert thresholds as well as to analyse alerts and trends, Figure 37.

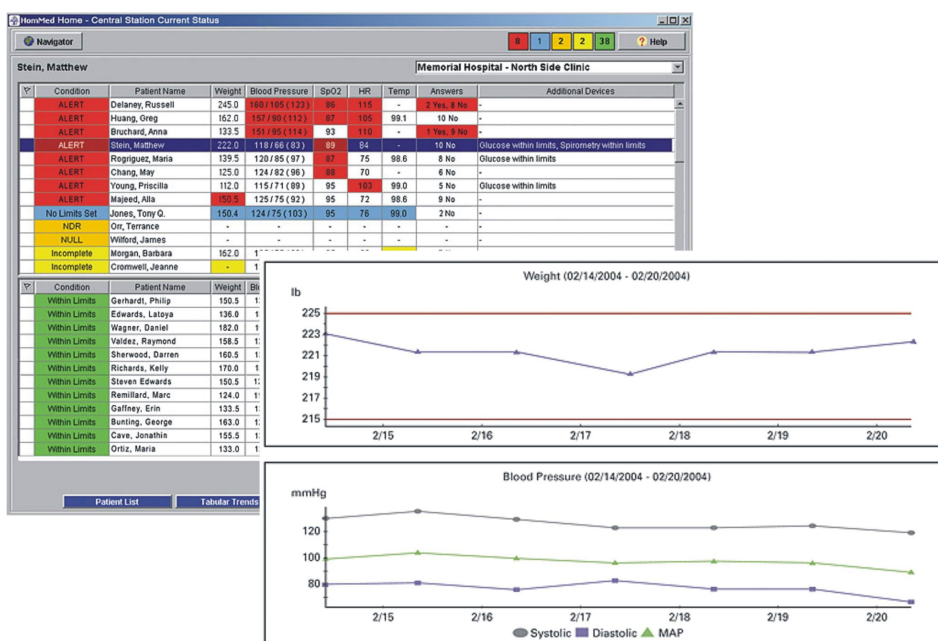

Figure 37. Example summary report with alerts and graphical trending reports (Honeywell).

The nature of the alerts generated typically include:

- No limits set;
- No data received;
- No measurement taken within scheduled monitoring timeframe;
- Incomplete measurement;
- Monitored Data within set limits ('green');
- Monitored data outside set limits ('red');
- Subjective health survey answer to prompt further investigation.

8.4 Section 5 – Discussion

8.4.1 Financial Analysis of Telecare Services

8.4.1.1 Who will be the main beneficiaries & what is the added value for each service?

Telecare services are likely to be beneficial to many different stake-holders including the service users themselves, their family and friends (i.e. informal carers) and the public purse.

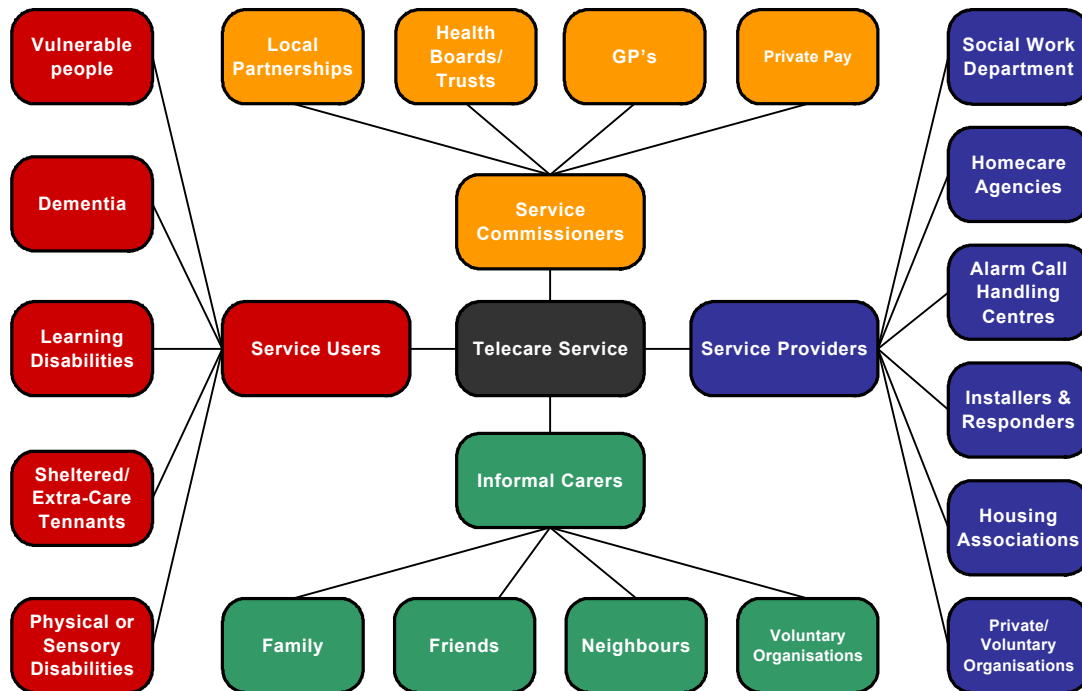

Figure 38. Stake-holders in a Telecare Service.

Figure 38 shows a stakeholder arrangement where the stakeholders are separated into 4 major groups:

- Service commissioners;
- Service providers;
- Informal carers; and
- Service users.

The desired outcomes for each stakeholder group are different and are summarised in Table 14 though, in practice, improvements in the health and well-being of both the service user and any informal carers, will also benefit the other stakeholders in ways that may be difficult to quantify. It is therefore difficult to measure all the benefits from telecare provision in a standard unit of currency. However, some services will yield outcomes that are easier to compare in objective terms. In such cases, it is also necessary to understand when the likely benefits are likely to accrue. Clearly a strategy based on prevention seeks to avoid future costs due to escalating levels of care need by providing early, low-level interventions which enable

people to remain in the lower levels of the needs pyramid for longer. The benefits are definitely long-term. On the other hand, many of the telecare applications which are aimed at keeping people out of hospital either through improvements in medication reminders, or through support of the community care support structures, may produce very rapid savings to the health economy whilst also benefiting social work budgets in a few years, but unit costs may be higher than low level.

Table 14. Desired outcomes & impacts of telecare project.

Service Users	Informal Carers	Service Providers	Housing Providers	Health Economy
Increased choice in location and type of care	Peace of mind	Greater sense of satisfaction for professional staff	Reduced voids in sheltered housing	Reduced level of unscheduled care
More responsive services	Improved Quality of Life	Increased system capacity and more effective use of staff time	Increased demand for specialist homes	Reduced emergency admissions
Improved Quality of Life	Respite opportunities	Reduced admissions to residential care	Reduced damage to properties	Reduced number of hospital re-admissions
Increased independence	Reduced stress	Reduced Delayed Transfers of Care	Reduced demand for other services	Reduced Delayed Transfers of Care
Increased chance of "staying put"	Increased independence	Reduced demand for other services e.g. homecare	New role for mobile wardens	Improved medication compliance
Reduced care costs	Improved assessments	A move towards preventative rather than reactive services	Improved home security	Reduced ambulance needs

Indications from some of the London Boroughs suggest that benefits to the health economy peak after 6 months and continue to decline for at least 2 years ^[32]. On the other hand, benefits to the local authority (or partnership) may peak after 2 to 3 years with a lifetime of 5 years. Cost benefit analysis is therefore extremely difficult. However, for the sake of completeness, the financial benefits and their likely scale for the telecare applications described in *Section 4* will be discussed below. The level of savings depends on the individual circumstances and, in particular, on the quality of the assessment process and the way in which it best matches technology (i.e. telecare service) to the identified risk factors and unmet needs.

8.4.1.2 Financial Benefits Due to Telecare Service Applications

Table 15 list the beneficiaries of each telecare service, and also the possible scale of benefit based on available evidence. It may be observed that the most significant financial benefits from telecare service provision are likely to accrue to the NHS through reduced use of secondary care beds and to local authorities from better support of people in their own homes. However, the overall benefits to all stakeholders can be considerable. It may be apparent that different telecare applications could be funded by the stakeholder who is most likely to gain financial benefit from this provision.

Table 15. Financial Beneficiaries from Telecare Service Provision.

Telecare Application	Perceived Benefits	Stakeholders Benefiting Financially	Level of Benefit
Basic social/alarms	Reassurance + peace of mind	Social work, landlord	Low
	Rapid access to emergency services	Health service	Low
Alarm telecare	Rapid detection of environmental accidents	Housing, fire service	£2000 per flood £30,000 per fire
	Rapid response to falls	Health service, social work	£2000 per incident
	Management of safety issues relating to dementia	Health service, social work	£500 per week
	Prevention of delayed transfer of care	Health service	£300 per day
	Reduction in demand for homecare services	Social work	£16 per hour
Lifestyle Monitoring	Reduction in inappropriate admission to residential care	Social work	£300 per week
	More responsive approach to care provision	Social work	Unknown
	Prevention of hospital admission through early intervention	Health service	£300 per day
Telehealth	Prevention of hospital admission through early intervention	Health service	£300 per day
	Reduced demand on A&E presentations	Health service	£200 per visit
	Reduced demand on other primary care services	Health service	£100 per incident
Proactive Calling	Improved confidence	All	Unknown
	Delay in need for community services	Social work	£50 per week
	Early detection of exacerbations of chronic disease	Health service	£300 per day
Domiciliary care monitoring	Reassurance	All	Unknown
	Quality assurance of service delivery	Social work and health service	Unknown
Access management	Rapid access to property in event of emergency	Fire service	Unknown
	Avoidance of damage to doors gaining access	Housing	£500 per incident

Telecare Application	Perceived Benefits	Stakeholders Benefiting Financially	Level of Benefit
Schools Security	Detection of intruders	Local authority, police	£5000 per incident
	Prevention of flood damage	Local authority	£5000 per incident
	Prevention of fire	Local authority, Fire and Rescue Service	£100,000 per incident
Lone worker monitoring	Staff protection	Social work, Housing and health service	Unknown
	Optimum response to emergencies	Social work, Housing and health service	Unknown
Smoke detector management	Reduction in number of false call outs	Fire service	£400 per call-out
Location based systems	Avoidance of EMH admissions	Health service	£500 per week
	Rapid location of lost people	Police	£200 per incident
Video-based services	Re-ablement services	Social work and health service	Unknown
	Health advice and coaching	Health service	Unknown

8.4.1.3 Costs in Providing Telecare Services

The cost of operating social and community alarm handling centres is remarkably difficult to determine with any certainty due to a number of factors including:

- The separation of call handling functions from other service elements such as administration, maintenance, installation, procurement and response;
- The use of staff who have other roles and whose salary should be appropriately shared between different cost centres;
- The actual cost of premises and utility services;
- The need to make a contribution to the organisation's overheads (typically 30% or more); and
- Indirect subsidies to some operating costs.
- One-stop shop which includes other call handling services for the local authority

Nevertheless, for consistency, we should consider the operating costs under a standard number of headings:

- Direct cost of salaries;
- Indirect cost of staff (N.I., pensions etc.);
- Agency & overtime costs (to cover holidays etc.);
- Office Premises and council tax;
- Utilities (heating, lighting etc.);
- Telecoms costs;
- Human Resource costs (training & recruitment);
- Marketing (advertising, promotion and printing);
- Office costs (paper, pens etc.); and
- Book-keeping & accountancy costs.

The above costs are obviously dependent on the scale of operations, and will therefore vary with the number of service users. Other costs are contained within an overhead payment to the "owners" of the alarm handling centre, or are directly associated with capital or revenue costs of the particular telecare service. These are described in Table 16. Most on-going costs depend on the number of service users, but many are independent of the actual number of users.

Table 16. Estimated Capital and Revenue Costs for the Different Telecare Applications.

Telecare Application	Capital Requirements	Capital Costs	On-going resources	On-going costs	Likely annual cost
Basic social alarms	Monitoring centre hardware/software	£40K	Maintenance contract	£6K p.a.	> £218K
	Training programme	£4K	Staffing	> £200K p.a.	
			Training	£2K	
Alarm telecare	Upgrade to more advanced alarm handling centre with remote home unit programming	£20K+	Extra maintenance contract	£3K p.a.	As above + >£64K
	New training programme	£2K	Upgrades	£5K p.a.	
			Extra Staff	> £50K p.a.	
			Training	£1K p.a.	

Telecare Application	Capital Requirements	Capital Costs	On-going resources	On-going costs	Likely annual cost
Lifestyle Monitoring	Additional servers, secure storage & telecoms	£5K	Extra maintenance	£1K p.a.	As above + £35K (for 20 clients)
	New training programme	£2K	Extra telecoms Service charges (only for some products) Extra staff Training	£2K p.a. ~£500 per system p.a. ~ £20K p.a. £1K p.a.	
Telehealth	Software licence etc	~ £5K	Service charges (only for some products)	~£1000 per system p.a.	As above + £52K (for 20 clients)
	Additional servers, secure storage & telecoms	£5K	Extra maintenance	£2K p.a.	
	Training programme	£2K	Extra telecoms Extra Staff Training	£2K p.a. > £25K p.a. £1K p.a.	
Proactive Calling	Software licence etc.	£4K	Extra telecoms	£2K p.a.	As above + £14K (for 50 users)
	Training programme	£2K	Extra staff Training	~ £10K p.a. £1K p.a.	
Domiciliary care monitoring	Software licence etc.	£20K	Maintenance etc	£2K p.a.	As above + £31K (for 100s of users)
	Training programme	£2K	Telecoms Extra staff Training	£4K p.a. £20K £1K p.a.	
Access management	Software module	£2K	Extra staff time	£4K p.a.	As above + £5.5K
	Training programme	£1K	Training	£1K p.a.	

Telecare Application	Capital Requirements	Capital Costs	On-going resources	On-going costs	Likely annual cost
Existing/emerging applications					
Schools Security	N/A	N/A	Extra time staff	£2K p.a.	As above + £3K (for 100 locations)
	Training programme	£2K	Training	£1K p.a.	
Lone worker monitoring	N/A	N/A	Extra time staff	£2K p.a.	As above + £3K
	Training programme	£1K	Training	£1K p.a.	
Smoke detector management	N/A	N/A	Extra time staff	£2K p.a.	As above + £3K
	Training programme	£1K	Training	£1K p.a.	
Location based systems	N/A	N/A	Extra time staff	£2K p.a.	As above + £8K (for 10 users)
	Training programme	£2K	Training	£1K p.a.	
			Service charges	£5K p.a.	
Video-based services	Additional software and hardware	>£20K	Maintenance	£5K	As above + £30K (for hundreds of new users)
	Telecoms infrastructure	£12K	Telecoms	£5K p.a.	
	Training programme	£4K	Extra time staff Training	£10K p.a. £2K p.a.	

From the above it may be evident that all applications involve additional training and staff resource plus, in most cases, a capital cost for software or new equipment for the alarm handling centre. The lifetime of the equipment may be assumed to be in the order of 5 years though the rate of technological advance appears to be accelerating. It is therefore recommended that the capital expenditure is discounted over only 4 years in all business plans relating to telecare services. The right hand column is therefore an estimate of the total annual costs (in addition to the fixed and variable costs identified previously) of running a telecare alarm handling centre. The challenge is clearly one of operating those services that may be demanded by commissioners but within the constraints of available budget.

8.4.1.4 Potential Income Levels

All Scottish alarm handling centres are supported by income from their partner organisations. This may be in the form of a block grant (from which the annual revenue per service user can

be easily calculated) or it may be in the form of a service charge per service user. A combination is also possible. For completeness, the revenue information for each partnership is shown in Table 17 where it is available (partnerships are not included if either revenue or service user information has not been supplied)^[33]. They are approximate data and are only employed for comparison purposes. It may be observed that while the average unit cost per annum is about £125 (i.e. about £2 per week), the range of costs per partnership extends from £25 or less per annum for 4 partnerships (Aberdeenshire, North Lanarkshire, Stirling and Perth & Kinross) up to £544 for East Dunbarton-shire. There is no obvious relationship between the unit cost and the number of service users, which implies that economy of scale may not be the only factor in determining revenue. It is likely that individual charges paid by service users are significant in many partnerships.

Table 17. Revenues and Unit Costs Across Partnerships in Scotland.

Partnership	Approx. annual revenue budget 2006/2007	No. of Service Users	Approx. Unit Cost p.a.
Aberdeen City	£217,000	5749	£38
Aberdeenshire	£170,000	7200	£23
Angus	£768,000	4100	£187
Argyll and Bute	£251,555	1083	£232
Clackmannan- shire	£61,000	1200	£50
Dumfries and Galloway	£359,621	3,800	£94
Dundee	£650,000	6000	£108
East Ayrshire	£321,993	3075	£104
East Dunbarton-shire	£707,471	1300	£544
East Lothian	336,000	3020	£111
East Renfrewshire	109849	1500	£73
Eilean Siar	284,000	930	£305

Partnership	Approx. annual revenue budget 2006/2007	No. of Service Users	Approx. Cost p.a.	Unit
Falkirk	£245,420	5735	£42	
Fife	£506,660	8,500	£88	
Glasgow	£1,452,420	19,000	£76	
Highland	£121956	3254	£37	
Midlothian	£447260	1275	£350	
Moray	£55,380	1379	£40	
North Ayrshire	£566,260	2268	£249	
North Lanarkshire	£250,000	11,120	£22	
Perth and Kinross	383,927	3500	£22	
Renfrewshire	£221,688	3100	£71	
Scottish Borders	£459,329	3094	£148	
South Ayrshire	£309,794	1690	£183	
South Lanarkshire	£651,478	6500	£100	
Shetland	£72000	750	£96	
Stirling	£92000	3570	£25	
West Lothian	£225,000	3000	£75	

These charges need to be separated into the various elements of a service in order to understand how much funding is available to support this centre. This means removing the potential costs associated with surveying the home and prescribing a telecare solution, procuring and installing equipment in the home, and offering a physical response to emergencies in addition to those already available through informal carers and by the

emergency services. Such a process is not possible for the wide range of service models available in Scotland though one centre (Dundee) allocates 60% of revenue to the alarm call handling centre. Therefore, in Table 18 we have assumed hopefully realistic levels of commercial charges that could be applied in order to compare income streams for different telecare applications, and to assign such charges to a particular sponsor within a partnership. Again, these charges are estimates and are provided as a range of potential charges reflecting special arrangements in some cases, especially where a service is piggy-backed onto existing provision. It may be evident that organisations may be reluctant to share detailed charge information because of commercial sensitivities.

Table 18. Estimated cost per user for telecare applications (Alarm call-handling only).

Telecare Application	Service Cost per User per week	Annual cost per user	Comments	Likely Source of Funding
Basic social alarms	£1 to £1.50	£50 to £75	Pressure on Supporting People budgets to reduce monitoring fees	Social work, landlord Health service, SP, Individual
Alarm telecare	£1.20 to £2.50	£60 to £125	Burden on alarm monitoring centre will vary according to level of risk and number of devices	Landlords, Health service, social work, SP
Lifestyle Monitoring	£3 to £5	£150 to £250	Differential rates may be needed for short term assessment and for long term applications	Social work Health service
Telehealth	£7 to £15	£350 to £750	Cost may depend on whether nurses are employed within centre	Health service
Proactive Calling	£2 to £3	£100 to £150	Cost will depend on number of calls per week & on length of calls	Social work Health service
Domiciliary care monitoring	£1 to £2	£50 to £100	Cost may depend on number of functions performed	Social work
Access management	0 to £2	Up to £100	May become an optional extra funded by individual; video services are extra	Social work Private pay Health service

Telecare Application	Service Cost per User per week	Annual cost per user	Comments	Likely Source of Funding
Lone worker monitoring	£2 to £5	£100 to £250	Different technologies require more resources from the centre	Social work and health service
Schools Security	£5 to £10	£250 to £500	Some services will involve video monitoring and remote activation devices	Local authority, police Fire & Rescue Service
Smoke detector management	None	None	Fire service may provide enhanced partnership to cover training costs	Fire & Rescue Service
Location based systems	£5 to £10	£250 to £500	Some services will involve alarms and speech options	Health service Police, Social work
Video-based services	£3 to £6	£150 to £300	Face-to-face consultations possible with nurses	Social work and health service

The annual costs of providing the telecare applications shown in Table 18 are all in the range of unit costs for the existing partnerships with the exception of telehealth applications. It follows that individual partnerships may choose to add some or all of the applications to their existing provision according to their own local priorities and in line with the business cases presented to them by the relevant stakeholder organisations. These choices may also be influenced by other non-financial factors including:

- The compatibility of the application field equipment, or software/hardware at the centre, with existing alarm call handling systems – older alarm centre systems (and some new ones) will not offer the full features of centres that are being designed specifically to accommodate remote field device reprogramming;
- Limitations of space or the physical environment of the existing centre;
- Opportunities to build on existing projects or infrastructures;
- The availability of other partner agencies to perform other elements of service delivery; and
- The overall local vision for supporting independence through technology.

It follows that some partnerships may be restricted in their development of telecare services by some or all of the above factors. This could lead to a postcode lottery unless alternative delivery strategies are considered. Options are discussed in *Section 6*.

9. References

- [1] "Review of Call handling arrangements for Telecare in Scotland"; Paper to Telecare programme Board, 15 May 2008; www.jitscotland.org.uk
- [2] "Review of Call handling arrangements for Telecare in Scotland"; Paper to Telecare programme Board, 15 May 2008; www.jitscotland.org.uk
- [3] Registrar General's Annual Review of Demographic Trends for Scotland's Population (2006); available at: <http://www.gro-scotland.gov.uk/files1/stats/annual-report2006/j873200.htm>
- [4] <http://www.scotland.gov.uk/News/Releases/2008/03/17152649>
- [5] e.g. <http://www.sensatex.com>
- [6] <http://www.continuaalliance.org>
- [7] <http://www.btplc.com/21CN/>
- [8] Personal communication with Brian Kerr, JIT Telecare Team, March 2008.
- [9] Statistical Bulletin Housing Series HSG/2007/4: "Supporting People Client Statistics, 2005-06", March 2007; available at: <http://www.scotland.gov.uk/Publications/2007/03/23141000/21>
- [10] Abigail Self (Ed.) "Social Trends No. 38" 2008 Edition, Office for National Statistics
- [11] "Review of Call handling arrangements for Telecare in Scotland"; Paper to Telecare programme Board, 15 May 2008; www.jitscotland.org.uk
- [12] Katherine Hill, Karen Kellard, Sue Middleton, Lynne Cox and Elspeth Pound "Understanding resources in later life: views and experiences of older people" First published 2007 by the Joseph Rowntree Foundation; ISBN: 978 1 85935 561 9
- [13] "Managing Long Term Conditions", Audit Scotland, Prepared for the Auditor General for Scotland and the Accounts Commission August 2007
- [14] Audit Scotland "Managing Long Term Conditions" (2007).
- [15] E Pears, P C Hannaford, M W Taylor, "Gender, age and deprivation differences in the primary care management of hypertension in Scotland: a cross sectional database study" *Family Practice*, Vol.20, No. 1 (2003).
- [16] Chronic disease management. A compendium of information, Department of Health, May 2004.
- [17] "COPD patients benefit from home monitoring" *The British Journal of Healthcare Computing & Information Management* Vol. 23 No. 7 September 2006.
- [18] http://www.audit-scotland.gov.uk/docs/health/2007/nr_070816_managing_long_term_km.pdf
- [19] Maurice J O'Kane, Brendan Bunting, Margaret Copeland, Vivien E Coates, "Efficacy of self monitoring of blood glucose in patients with newly diagnosed type 2 diabetes (ESMON study): randomised controlled trial" *British Medical Journal* 17th April 2008; <http://www.bmj.com/cgi/content/full/bmj.39534.571644.BEv1>
- [20] Judit Simon, Alastair Gray, Philip Clarke, Alisha Wade, Andrew Neil, Andrew Farmer, "Cost effectiveness of self monitoring of blood glucose in patients with non-insulin treated type 2 diabetes: economic evaluation of data from the DiGEM trial" *British Medical Journal* 17th April 2008; <http://www.bmj.com/cgi/content/full/bmj.39526.674873.BEv1>

- [21]"Service outcomes and achievements within Chester care" Presentation by Fran Taberner, CSIP Conference on "Outcomes from Telecare and Advanced Assistive Technology - Two Years of Progress", Manchester, 4th February 2008.
- [22]"Own Health Birmingham - Successes and learning from the first year" A report by Birmingham East & North PCT, NHS Direct and Pfizer Health Solutions, September 2007.
- [23]Jan Dewing "Screening for wandering among older persons with dementia", *Nursing Older People*, May Vol. 17 No. 3; pp 20-24 (2005)
- [24]http://www.arsonpreventionbureau.org.uk/viewDocument.aspx?Document_ID=183
- [25]"Creating The Safest Community" Presentation by Kevin Gardner of the Tyne and Wear Fire and Rescue Authority at "A BRIGHT FUTURE FOR TELECARE IN NEWCASTLE", Centre for Life, Newcastle, Wednesday April 2nd 2008.
- [26]Williams G., Doughty K. "Towards an evaluation framework for telecare services" *Journal of Assistive Technologies*, Vol. 1, No. 1, pp. 42-47, 2007.
- [27]T-Cubed, "Work Package 7 – Final Report & Recommendations" North Wales Regional Collaborative Approach to Telecare – Feasibility Study, July 2007.
- [28]Karen Croucher, Diana Sanderson, Karin Lawson, Stephen Chaplin, Dianne Wright, "Review of Sheltered Housing in Scotland", Research Findings No.9/2008, University of York, January 2008.
- [29]<http://www.toumaz.com/>
- [30]http://www.cambridgeconsultants.com/news_pr204.shtml
- [31]"Lifestyle Change – Care management and Technology" Dr Richard A Mendelsohn, Director of Chronic Disease Systems; Birmingham East and North PCT TLC Professionals Forum, Stoke, 18th March 2008.
- [32]Charles Lowe, CUHTec Advanced Telecare User Group, Private communication (2007)
- [33]"Review of Call handling arrangements for Telecare in Scotland"; Paper to Telecare programme Board, 15 May 2008; www.jitscotland.org.uk